

E-Series Analog + Start / Stop

Temposonics® EH
Stroke length 50 - 2500 mm

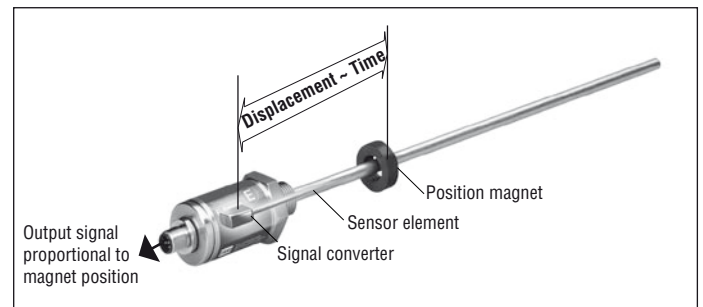

- Linear, absolute Measurement
- Contactless Sensing with highest Durability
- Rugged Industrial Sensor
- EMC shielded and CE certified
- Linearity Deviation less than 0,02 % F.S.
- Repeatability 0,001 % F.S.
- Direct signal output for displacement
 - Analog (V/mA)
 - Start / Stop + Sensor-Parameter Upload
- Stroke length 50 - 2500 mm



Magnetostriction

The absolute Temposonics® linear position sensors are based on the MTS developed magnetostrictive measurement principle. That combines various magneto-mechanical effects and uses the physical high precise speed-measurement of an ultrasonic wave (torsion pulse in its sensor element) for position measurement. Sensor integrated signal processing transforms the measurements directly into market standard outputs. The contactless principle - a movable magnet marks the position - eliminates the wear, noise and erroneous signal problems and guarantees the best durability without any recalibration.

Form factor

The extremely robust sensor, ideal for continuous operation under harshest industrial conditions is completely modular in mechanic and electronic design.

- A profile or rod-shaped sensor housing protects the sensing element in which gives rise to the measurement signal.
- The sensor head accommodates the complete modular electronic interface with active signal conditioning.
- The position transmitter, a permanent magnet - fixed at the mobile machine part - drives contactlessly over the sensor's stroke and starts measuring through the housing wall.

Temposonics-EH

Analog + Start / Stop

Temposonics®-EH

High Pressure Compact Sensor - Stroke length 50 - 2500 mm.

The new compact stainless steel position sensors are designed for installation into hydraulic cylinders, specifically for use in standard clevis head cylinders or any space limited cylinder applications. The EH type sensors are ideal choices for a wide range of standard hydraulic cylinders. Magnetostrictive displacement sensors, high quality cylinders and precise control valves form ideal driving systems for technically demanding machine industries.

The extremely rugged sensor consists of 3 main parts

1. The sensor head, a robust housing with built-in electronics.

2. The pressure-proof sensor pipe (up to 530 bar) with threaded flange protects the internal sensing element, the waveguide system. It fits into the hollow drilled piston rod.

3. The position magnet, the only moving part is mounted on the piston head.

This permanent magnet travels wearfree and contactless along the stationary sensor tube. Its magnetic field starts the measurement signal through sensor's rod wall. Temposonics®-EH sensors provide analogue output of Voltage and Current. The output signal is proportional to the magnet position along the active measuring stroke of the sensor. The measuring range is factory set and does not need recalibration. Since the outputs are direct, no signal-conditioning electronics are needed when interfacing with controllers or meters.

Technical Data

Input

Measuring Variable	Displacement
Stroke length	50 - 2500 mm

Output

1. Voltage	0 - 10 VDC or 10 - 0 VDC, 0 - 10 VDC and 10 - 0 VDC (Controller input resistance $R_L > 5 \text{ k}\Omega$)
2. Current	4 - 20 mA or 20 - 4(0) mA (Min/max. load: 0/500 Ohm)
3. Start / Stop	RS-422 differential signal, additionally, available: Serial parameter upload of stroke length, Offset, Gradient (Ultrasonic speed of sensing pulse), status and manufacturer number

Accuracy

Resolution	Analog: Infinite Start / Stop: 0,1 / 0,01 / 0,005 mm
Linearity, deviation	$< \pm 0,02 \%$ F.S. (Minimum $\pm 60 \mu\text{m}$)
Repeatability	$< \pm 0,001 \%$ F.S.
Update frequency, stroke dependent	Analog: $< 3 \text{ kHz}$ / Digital: Controller depended
Ripple	$< 0,01 \%$ F.S. / Digital: Controller depended

Operating conditions

Mounting position	Any
Magnet speed	Any
Operating temperature	$-40^\circ \text{C} \dots +75^\circ \text{C}$
Dew point, humidity	90 % rel. humidity, no condensation
Ingress protection	IP69K if mating cable connector is correctly fitted
Shock test	100 g (single shock) IEC-Standard 68-2-27
Vibration test	15 g / 10 - 2000 Hz IEC-Standard 68-2-6 (resonance frequency excluded)
EMV-Test	Electromagnetic emission EN 61000-6-4, CISPR 16 Electromagnetic susceptibility EN 61000-6-2 EN 61000-4-2/3/4/6, CE qualified

Form factor / Material

Sensor housing	Stainless Steel 1.4301 / AISI 304
Rod	Stainless Steel 1.4301 / AISI 304 7 mm Rod: 300 bar, 450 bar peak 10 mm Rod: 350 bar, 530 bar peak
Position encoder	Ring magnet, PA-Ferrite

Installation

Mounting type	Threaded flange M18 x 1,5
Mounting position	Any

Electrical Connection

Connection type	5 pin connector M12 (Analog) ; 8 pin M12 (Start / Stop)
Input voltage	24 VDC (+20 % / -15 %)p
Current consumption	50 - 140 mA (Digital 50 - 100 mA)
Ripple	$< 1 \%$ S-S
Electric strength	500 VDC (0V ground to machine ground)
Polarity protection	up to -30 VDC
Overvoltage protection	upt to 36 VDC

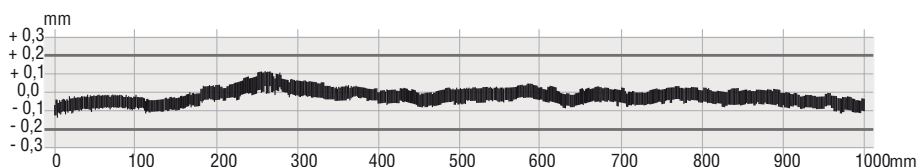

Linearity protocol

Sensor Temposonics®-EH, Stroke length 1000 mm
Tolerance allowed: $\pm 0,2 \text{ mm}$
Tolerance measured: typical $\pm 0,09 \text{ mm}$

Temposonics® EH

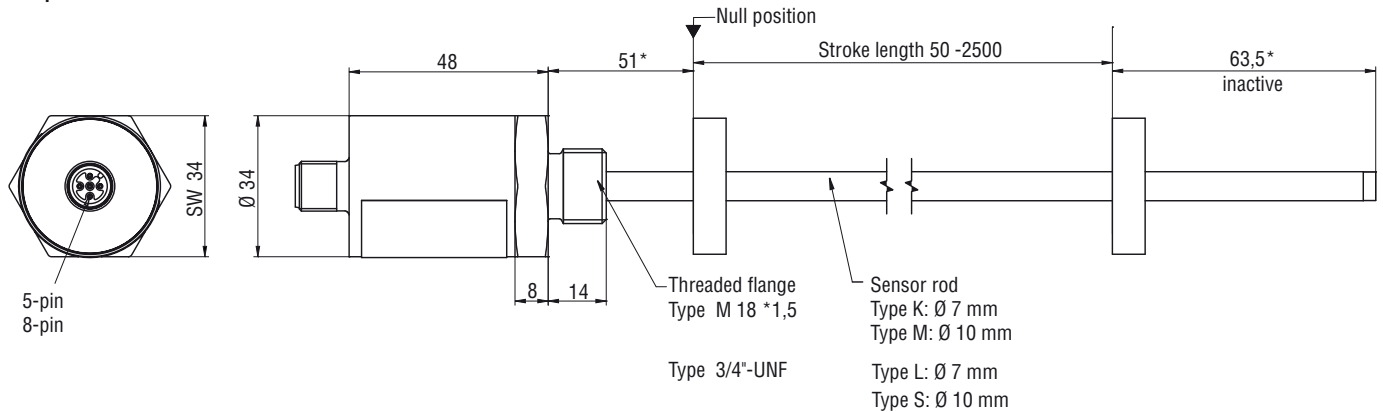

*** 30 mm null position and 60 mm inactive zone use prefix CP11009 to the ordering code.**

Mounting

The sensor may be operated in any position. Normally, the sensor is firmly installed, whilst the magnet is mounted at the mobile machine part and taken over the tube contactlessly.

Note: To avoid damaging of magnet and sensor housing be aware of a careful parallel mounting of the transducer.

Rod

Temposonics® EH is designed for installation into standard hydraulic cylinders or parallel to moved machine parts. The sensor can be mounted in any position. The sensors high-pressure, stainless steel tube will be fixed via the threaded flange M18 x 1,5.

Hydraulic sealing recommendation

By use of an O-Ring (e.g. 21,89 x 2,62) in a channel of cylinder cover or O-Ring 15,3 x 2,2 sealing in sensor thread undercut.

Attention

For screwing in the sensor, please use only the hexnut on sensors head bottom. Maximum tightening torque is 50 Nm.

1. Non-magnetizable material

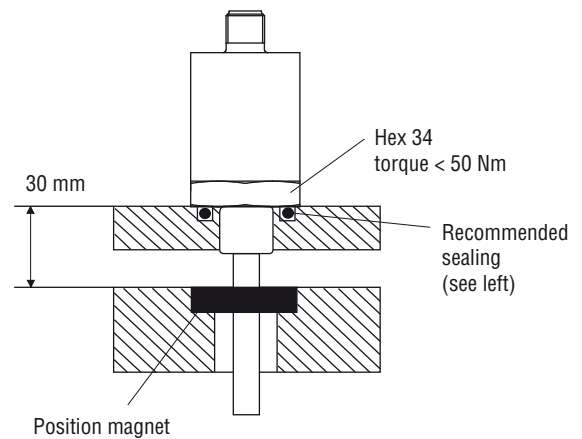

2. Magnetizable material

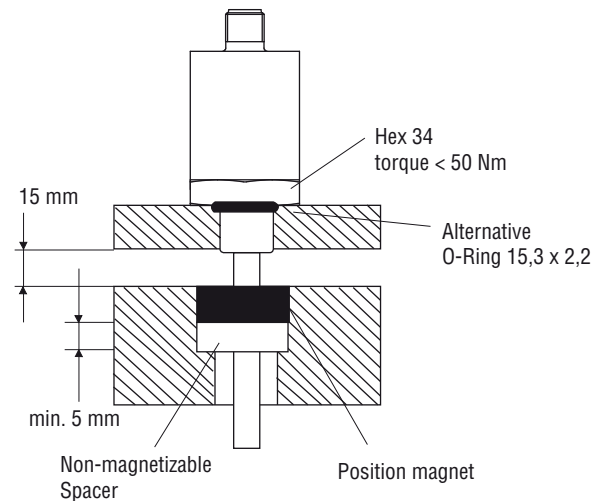

Position magnet

For accurate position measurements mount the magnet with non-magnetizable fastening material (screws, supports etc.). Using ferromagnetic supports, note that the magnet must be mounted with non-magnetizable spacer and screws (see right).

Cylinder mounting

Use a rod bushing (e.g. fluorelastomer) to prevent wear on the magnet and the sensor pipe. The bore in the piston rod is dependent on hydraulic pressure and piston velocity etc. The minimum drilling must be 10 mm for Ø 7 mm sensor rod and 13 mm for Ø 10 mm sensor rod. Do not exceed the 450 (530) bar peak pressure.

Position magnets

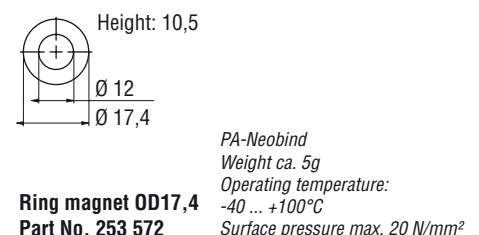
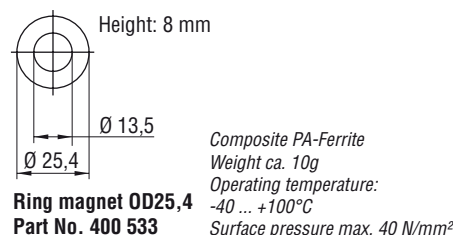
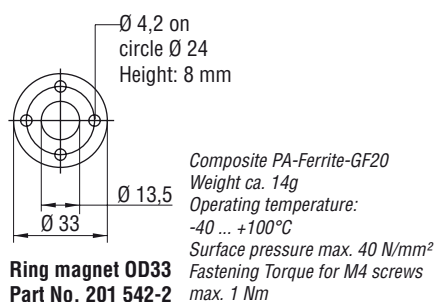

All measurements in mm

Connector wiring

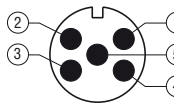

Front face of sensor plug
or rear of cable connector

Connector D34	Cable*	Analog (V)
Pin 1	bn	+24 VDC
Pin 2	wh	Signal
Pin 3	bu	GND (PWR)
Pin 4	bk	2. Signal
Pin5	gr	GND (Signal)

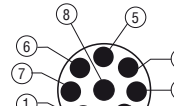

Front face of sensor plug
or rear of cable connector

Connector D84	Start / Stop
Pin 1	Start +
Pin 2	Start -
Pin 3	Stop +
Pin 4	Stop -
Pin 5	n.c.
Pin 6	n.c.
Pin 7	+24 DC
Pin 8	GND

* Accessory: Cable assembly with cable connector, female

Cable shield is soldered on connector housing and must be grounded in the control unit.

Connectors (please order separately)

Female connector M12

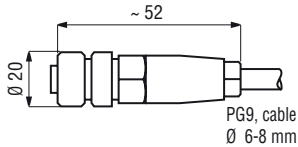

Housing: PA
Termination: Screw terminals
Contact insert: (CuZn/Sn)
Max. Cable-Ø 6-8 mm
Part No.: 5 pol. 370 618
8 pol. 370 671

90° female connector M12

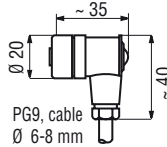

Housing: PA
Termination: Screw terminals
Contact insert: (CuZn/Sn)
Max. Cable-Ø 6-8 mm
Part No.: 5 pol. 370 619
8 pol. 370 672

Temposonics® Order

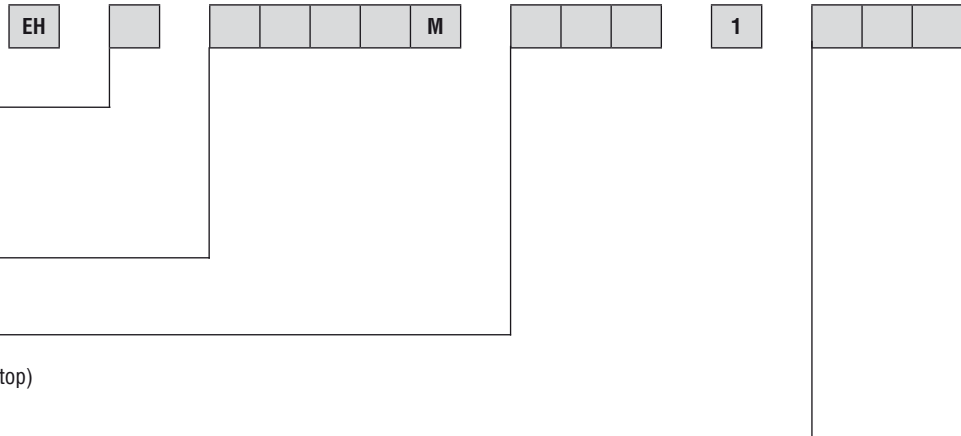

Specification

K = Flange M18 x 1,5 / Rod-Ø 7 mm
M = Flange M18 x 1,5 / Rod-Ø 10 mm
L = Flange 3/4"-UNF / Rod-Ø 7 mm
S = Flange 3/4"-UNF / Rod-Ø 10 mm

Stroke length

0050 - 2500 mm

Connection type

D34 - 5 pin cable connector M12 (Analog)
D84 - 8 pin cable connector M12 (Start / Stop)

Output

Analog voltage

V01 = 0 to 10 VDC (1 output channel with 1 magnet)
V11 = 10 to 0 VDC (1 output channel with 1 magnet)
V02 = 0 to 10 VDC (2 output channels with 2 magnets)
V12 = 10 to 0 VDC (2 output channels with 2 magnets)
V03 = 0 to 10 VDC and 10 to 0 VDC (2 output channels with 1 magnet)

Analog current

A01 = 4 to 20 mA (1 output channel with 1 magnet)
A11 = 20 to 4 mA (1 output channel with 1 magnet)
A02 = 4 to 20 mA (2 output channels with 2 magnets)
A12 = 20 to 4 mA (2 output channels with 2 magnets)

Start/Stop

R3 = Start / Stop with sensor parameters upload function.

Stroke length Standard:

Stroke	Ordering steps
≤ 500 mm	5 mm
> 500 - ≤ 750 mm	10 mm
> 750 - ≤ 1000 mm	25 mm
> 1000 - ≤ 2500 mm	50 mm

Accessories

Description	Part No.
Position magnet OD33	201 542-2
Position magnet OD25,4	400 533
Position magnet OD17,4	253 572
5 pin female connector M12	370 618
5 pin 90° female connector M12	370 619
8 pin female connector M12	370 671
8 pin 90° female connector M12	370 672
5 pin M12 cordset, 5 m PUR shielded cable	370 673
8 pin M12 cordset, 5 m PUR shielded cable	370 674

Description	Part No.
5 pin 90° M12 cordset, 5 m PUR shielded cable	370 675
8 pin 90° M12 cordset, 5 m PUR shielded cable	370 676
5 pin adapter cable M12 to M16	254 206
8 pin adapter cable M12 to M16	254 207

On delivery:

- Sensor
Please order separately: Accessories

All measurements in mm

www.mtssensor.com
www.temposonics-shop.de

© MTS Temposonics® E-Series EH Analog + Start/Stop EN 551247 Rev D
Alterations reserved

MTS
SENSORS

MTS Sensor Technologie GmbH & Co. KG
Auf dem Schüffel 9
58513 Lüdenscheid, Deutschland
Tel. + 49-23 51-95 87 0
Fax + 49-23 51-5 64 91
E-Mail: info@mtssensor.de
www.mtssensor.de

MTS Systems Corporation
Sensors Division
3001 Sheldon Drive
Cary, N.C. 27513, USA
Tel. + 1-919-677-0100
Fax + 1-919-677-0200
E-Mail: sensorsinfo@mts.com
www.mtssensors.com

MTS Sensors Technology Corp.
737 Aihara-cho,
Machida-shi, Japan
Tel. + 81-42-775-3838
Fax + 81-42-775-5516
E-Mail: info@mtssensor.co.jp
www.mtssensor.co.jp