

E-Series Analog + Start / Stop

Temposonics® EP and EL
Stroke length 50 - 2500 mm
50 - 3000 mm (Temposonics EP Start / Stop)

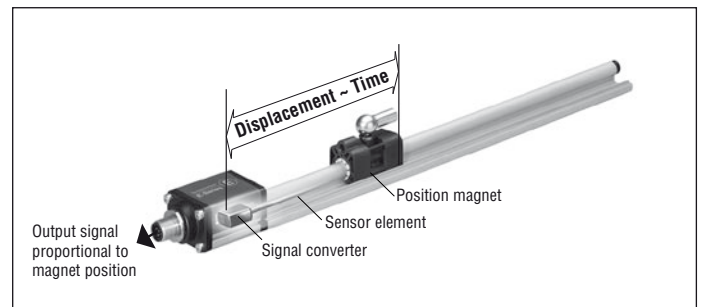

- Linear, absolute Measurement
- Contactless Sensing with highest Durability
- Rugged Industrial Sensor, EMC shielded and CE certified
- Linearity Deviation less than 0,02 % F.S.
- Repeatability 0,001 % F.S.
- Direct signal output for displacement
 - Analog (V/mA)
 - Start / Stop + Sensor-Parameter Upload
- Stroke length 50 - 2500 mm / 50 - 3000 mm



Magnetostriction

The absolute Temposonics® linear position sensors are based on the MTS developed magnetostrictive measurement principle. That combines various magneto-mechanical effects and uses the physical high precise speed-measurement of an ultrasonic wave (torsion pulse in its sensor element) for position measurement. Sensor integrated signal processing transforms the measurements directly into market standard outputs. The contactless principle - a movable magnet marks the position - eliminates the wear, noise and erroneous signal problems and guarantees the best durability without any recalibration.

Form factor

Temposonics® are extremely robust sensors, ideal for continuous operation under harshest industrial conditions. The sensor is completely modular in mechanics and electronics design.

- A profile sensor housing protects the sensor element in which gives rise to the measurement signal.
- The sensor head, a solid diecast aluminum housing, accommodates the complete modular electronic interface with active signal conditioning.
- The external position transmitter is a permanent magnet. It is fitted at the mobile machine part, taken over the sensing

Temposonics-EP / EL

Analog + Start / Stop

Temposonics®-EP and EL Das mechanisch robuste Profil

Measuring range: 50 - 2500 mm
50 - 3000 mm (Temposonics® EP Start / Stop Output R3)

A robust aluminum profile offers modular construction, flexible mounting configurations and easy installation. Position measurement is contactless via two versions of permanent magnets.

1. A captive sliding magnet running in profile housing rails. Connection with the mobile machine part is via a ball jointed arm to taking up axial forces.
2. A floating magnet, mounted directly on the moving machine part, travels over the profile at a low distance. Its permissible misalignment allows a not completely parallel installation.

Technical Data

Input

Measured variable	Displacement
Stroke length	50 - 2500 mm / 50 - 3000 mm for Temposonics® EP output R3 - Start / Stop

Output

1. Voltage	0 - 10 VDC or 10-0 VDC, 0 - 10 VDC and 10 - 0 VDC (Controller input resistance RL: > 5 kOhm)
2. Current	4 - 20 mA or 20-4 mA, (Min./max. load: 0..500 Ohm)
3. Start/Stop	RS-422 differential signal, additionally available: Serial parameter upload of Stroke length, Offset, Gradient (Ultrasonic speed of sensing pulse), status and manufacturer number

Accuracy

Resolution	Analog: Infinite Start / Stop: 0,1 / 0,01 / 0,005 mm
Linearity, deviation	< ± 0,02 % F.S. (Minimum ± 60 µm)
Repeatability	< ± 0,001 % F.S.
Update frequency, stroke dependent	Analog: < 3 kHz / Digital: controller dependent
Ripple	< 0,01 % F.S. / Digital: controller dependent

Operating Condition

Mounting position	Any
Magnet speed	Any
Operating temperature	-40° C ... +75° C
Dew point, humidity	90 % rel. humidity, no condensation
Ingress protection	IP67 if mating cable connector is correctly fitted
Shock rating	100 g (Single hit) / IEC-Standard 68-2-27
Vibration test	15 g / 10 - 2000 Hz IEC-Standard 68-2-6 (resonance frequency excluded)
EMV-Test	Electromagnetic emission EN 61000-6-4, CISPR 16 Electromagnetic susceptibility EN 61000-6-2 EN 61000-4-2/3/4/6, CE qualified

Form factor / Material

Sensor head	Aluminum
Sensor housing	Aluminum
Position magnet type	Magnet slider Hard Ferrite, Block magnet plastic, Ring magnet PA-Ferrite

Installation

Mounting type	Adjustable mounting clamps
---------------	----------------------------

Electrical connection

Connection type	5 pin connector M12 (Analog) ; 8 pin M12 (Start / Stop)
Input voltage	24 VDC (+20 % / -15 %)
Current consumption	50 - 140 mA (Digital 50 - 100 mA)
Ripple	< 1 % S-S
Electric strength	500 VDC (DC ground to machine ground)
Polarity protection	Up to -30 VDC
Overvoltage protection	Up to 36 VDC

Analog output

Temposonics®-EP are provided with an integrated analogue interface and can be connected to a control system or indicator directly without an interface. The microelectronics in the sensor head generates continuous, strictly displacement proportional voltage and current outputs whose upscale or downscale output action can be selected when ordering. The output variables are factory-set. Recalibration is not necessary.

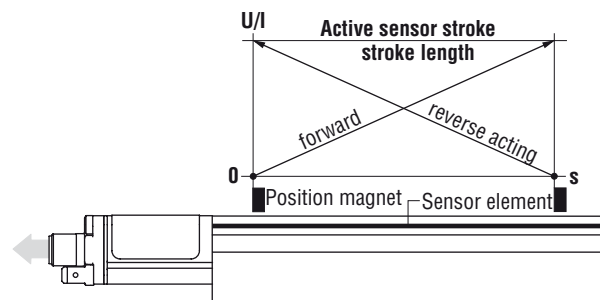

- Analog**
- 0-10 V
 - 10-0 V
 - 0 - 10 V and 10 - 0 V
 - 4-20 mA
 - 20-4 mA

Digital START / STOP output

Digital Temposonics®-EP is equipped with a start/stop output. The sensor requires a start signal from an external indicator in the control system and returns a signal corresponding to the magnet position. The time elapsed between the two signals is proportional to the magnet position, i.e. to the displacement. Time measurement is by the indicator and used for calculating the position value.

For easy adaption to user's control systems, following sensor parameters

- Stroke length
- Offset
- Gradient
- Status
- Manufacturer number

can be read into controller without additional wiring. It can be done simply by using the standard signal outputs.

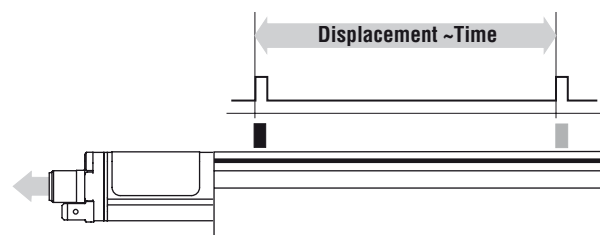
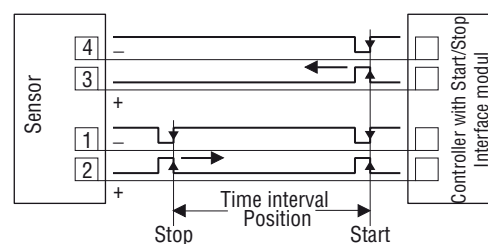

- Start/Stop + Parameters Upload**
- Stroke length
 - Offset
 - Gradient
 - Status
 - Manufacturer number

Linearity protocol

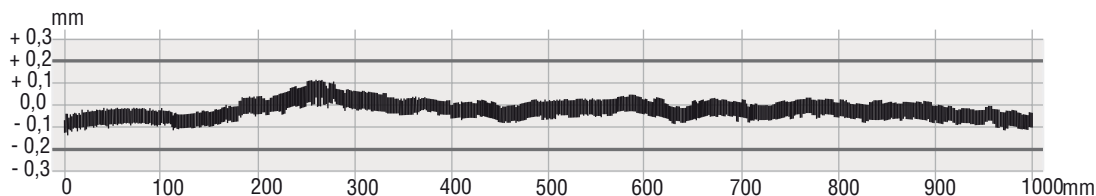

Sensor Temposonics®-EP, measuring range 1000 mm
 Tolerance allowed: $\pm 0,2$ mm
 Tolerance measured: typical $\pm 0,09$ mm

Profile

The sensor is fixed on a straight surface of the machine with the movable mounting clamps. These are provided in stroke length dependent number and are evenly on the profile to be distributed. We recommend screws M5 x 20 (DIN 6912) for attachment with a torque of max. **5 Nm** to be tightened.

ATTENTION!

The EP sensor is now fixed isolated from machine ground. It is necessary that sensor housing is grounded with flat pin terminal on the sensor head **(1)**.

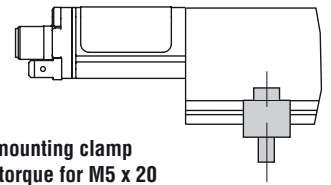
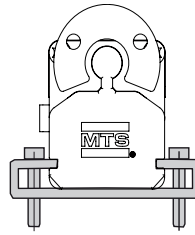

Sliding mounting clamp
Tightening torque for M5 x 20
Machine screws: max. 5 Nm

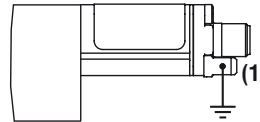

Position transmitter

U-Magnet: For accurate position measurements mount the magnet **(1)** with non-magnetizable fastening material **(2)** (screws, supports etc.). Using magnetizable supports, note that the magnet must be mounted with non-ferrous **(3)** of 5 mm minimum and screws.
Block magnet: The magnet **(4)** can be fixed with standard material and screws **(5)** Note the clearance, as shown right.

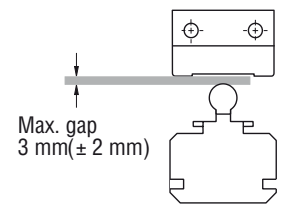
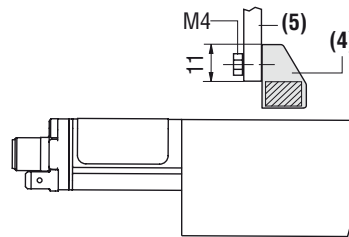
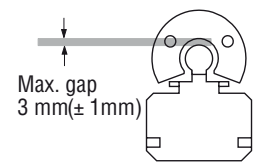
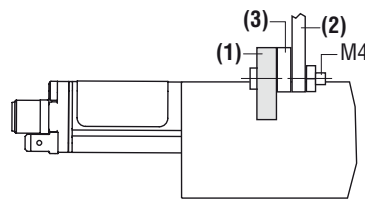

Attention!
do not exceed the allowed maximum gap

Anschlussbelegung

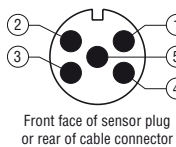

	Connector D34	Cable*	Analog (V)
	Pin 1	bn	+24 VDC
	Pin 2	wh	Signal
	Pin 3	bu	GND (PWR)
	Pin 4	bk	2nd Signal
	Pin 5	gr	GND (Signal)

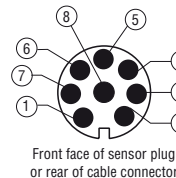

	Connector D84	Start / Stop
	Pin 1	Start +
	Pin 2	Start -
	Pin 3	Stop +
	Pin 4	Stop -
	Pin 5	n.c.
	Pin 6	n.c.
	Pin 7	+24 DC
	Pin 8	GND

* Accessory: Cable assembly with cable connector, female

Cable shield is soldered on connector housing and must be grounded in the control unit.

Temposonics® EP

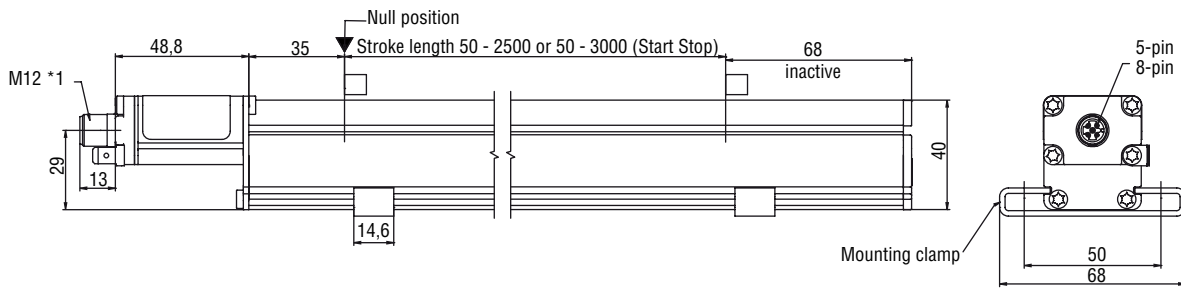

Temposonics® EL

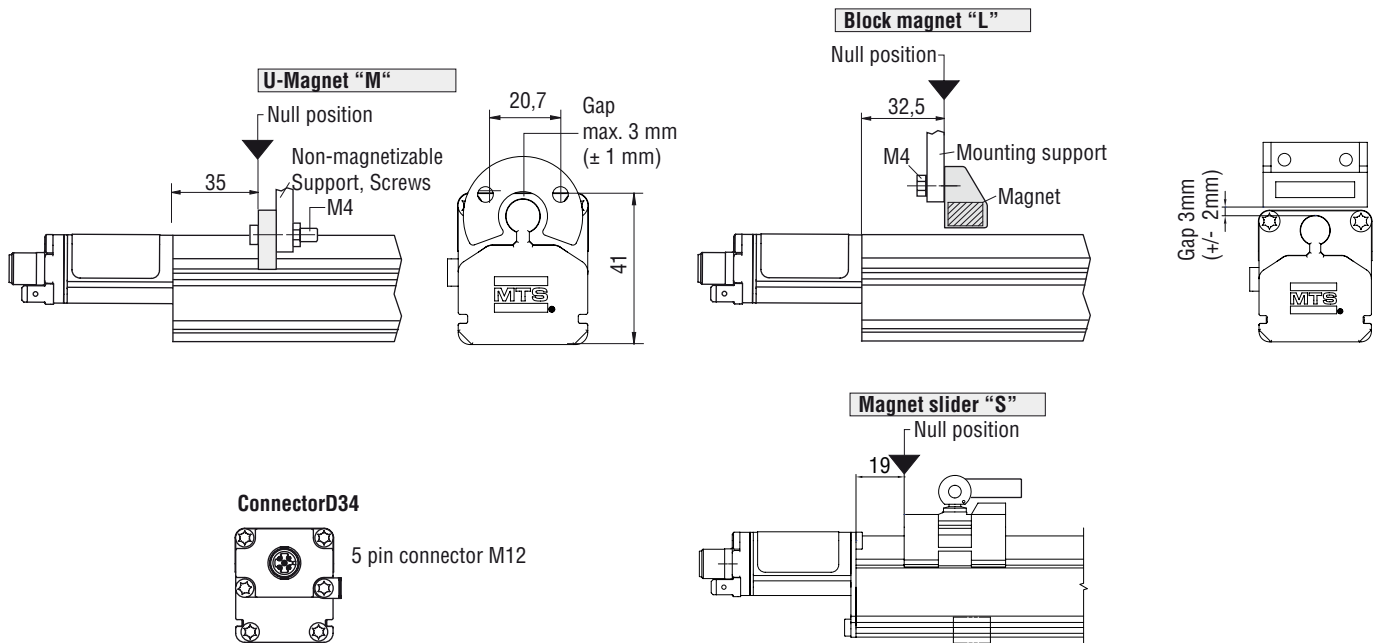
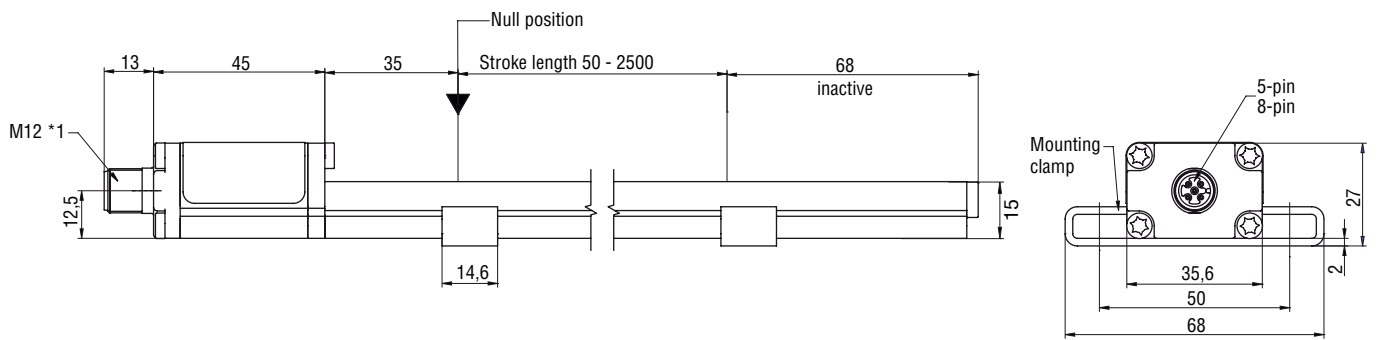

Position magnet

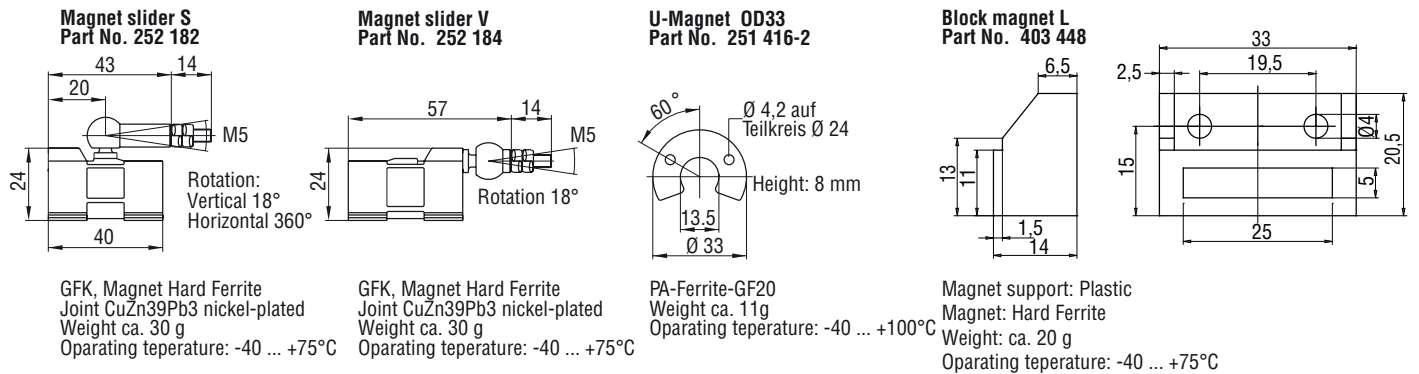

Other Position magnets upon request

Connector (please order separately)

Female connector M12

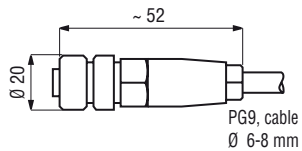

Housing: PA
Termination: Screw terminals
Contact insert: (CuZn/Sn)
Max. Cable-Ø 6-8 mm
Part No.: 5 pol. 370 618
8 pol. 370 671

90° female connector M12

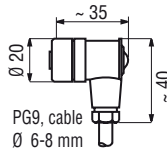

Housing: PA
Termination: Screw terminals
Contact insert: (CuZn/Sn)
Max. Cable-Ø 6-8 mm
Part No.: 5 pol. 370 619
8 pol. 370 672

Temposonics® Order



Specification

P = Temposonics® EP Sensor
L = Temposonics® EL Sensor

Stroke length

0050 - 2500 mm
0050 - 3000 mm (Output R3, s. below)

Connection type

D34 - 5 pin cable connector M12 (Analog)
D84 - 8 pin cable connector M12 (Start / Stop)

Output

Analog voltage

V01 = 0 to 10 VDC (1 output channel with 1 magnet)
V11 = 10 to 0 VDC (1 output channel with 1 magnet)
V02 = 0 to 10 VDC (2 output channels with 2 magnets)
V12 = 10 to 0 VDC (2 output channels with 2 magnets)
V03 = 0 to 10 VDC and 10 to 0 VDC (2 output channels with 1 magnet)

Analog current

A01 = 4 to 20 mA (1 output channel with 1 magnet)
A11 = 20 to 4 mA (1 output channel with 1 magnet)
A02 = 4 to 20 mA (2 output channels with 2 magnets)
A12 = 20 to 4 mA (2 output channels with 2 magnets)

Start / Stop

R3 = Start / Stop with sensor parameters upload function.

On delivery:

- Sensor
- 2 Mounting clamps up to 1250 mm stroke
- + 1 Mounting clamp for 500 mm each

Please order separately: Accessories (s. below)

Stroke length standard:

Stroke	Ordering steps
≤ 500 mm	25 mm
> 500 - ≤ 2500 mm	50 mm
> 2500 mm*	100 mm

*Only for Start / Stop output

Accessories

Discription	Part No.
Magnet slider "S"	252 182
Magnet slider "V"	252 184
U-Magnet OD33	251 416-2
Block magnet L	403 448
Mounting clamp	403 508
5 pin female connector M12	370 618
5 pin 90° female connector M12	370 619
8 pin female connector M12	370 671
8 pin 90° female connector M12	370 672
5 pin M12 cordset, 5 m PUR shielded cable	370 673
8 pin M12 cordset, 5 m PUR shielded cable	370 674
5 pin 90° M12 cordset, 5 m PUR shielded cable	370 675
8 pin 90° M12 cordset, 5 m PUR shielded cable	370 676
5 pin M12 adapter cable to M16	254 206
8 pin M12 adapter cable to M16	254 207

www.mtssensor.com
www.temposonics-shop.de

© MTS Temposonics® E-Series EP and EL Analog + Start/Stop EN 551245s Rev C
Alterations reserved



**MTS Sensor Technologie
GmbH & Co. KG**
Auf dem Schüffel 9
58513 Lüdenscheid, Deutschland
Tel. + 49-23 51-95 87 0
Fax + 49-23 51-5 64 91
E-Mail: info@mtssensor.de
www.mtssensor.de

MTS Systems Corporation
Sensors Division
3001 Sheldon Drive
Cary, N.C. 27513, USA
Tel. + 1-919-677-0100
Fax + 1-919-677-0200
E-Mail: sensorsinfo@mts.com
www.mtssensors.com

MTS Sensors Technology Corp.
737 Aihara-cho,
Machida-shi, Japan
Tel. + 81-42-775-3838
Fax + 81-42-775-5516
E-Mail: info@mtssensor.co.jp
www.mtssensor.co.jp