

## R-Series DeviceNet

**Temposonics RP and RH**  
Measuring length 25 - 7600 mm



### Intelligent Design



- Rugged Industrial Sensor
- Linear and Absolute Measurement
- LEDs for Sensor Diagnostic
- Contactless Sensing with Highest Durability
- Superior Accuracy: Resolution up to 2  $\mu\text{m}$
- Linearity better 0,01 %
- Repeatability 0,001 %
- Sensor-based intelligence
- Direct DeviceNet Output

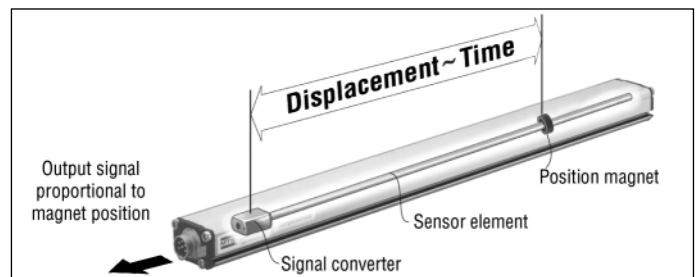

#### Magnetostriction

#### Form factor

The absolute **Temposonics®** linear position sensors are based on the MTS developed magnetostrictive measurement principle. That combines various magneto-mechanical effects and uses the physical high precise speed-measurement of an ultrasonic wave (torsion pulse in its sensor element) for position detecting. Sensor integrated signal processing transforms the measurements directly into market standard outputs. The contactless principle - an external movable magnet marks the position - eliminates the wear, noise and erroneous signal problems and guarantees the best durability without any recalibration.

The extremely robust sensor, ideal for continuous operation under harshest industrial conditions is completely modular in mechanic and electronic design.

- A profile or rod-shaped sensor housing protects the sensing element in which gives rise to the measurement signal.
- The sensor head accommodates the complete modular electronic interface with active signal conditioning. Double encapsulation ensures high operating safety and optimum EMC protection.
- The position transmitter, a permanent magnet - fixed at the mobile machine part - drives contactlessly over the sensor's stroke and starts measuring through the housing wall.

### New...a sensor diagnostic display

Bi-color LEDs in the cover of sensor electronics head inform on the actual sensor condition and the DeviceNet communication.

#### Network Status LED

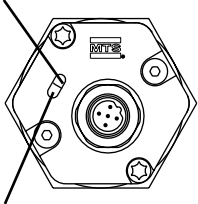

#### Module Status LED

#### Network Status LED

Green	Normal function
Green flashing	Waiting of instructions from DeviceNet Master
Red	Initialisation error
Red flashing	No answer from DeviceNet Master

#### Module Status LED

Green	Normal function
Red	No Magnet

### Plug and Play

makes the installation of the Temposonics position sensor with DeviceNet interface quick and easy. After initial system configuration, the user is not required to have extensive knowledge concerning network timing and sensor technology. Each sensor is provided with an Electronic Data Sheet EDS, an operation manual and a detailed Statement of Conformance. All sensor-specific parameters are installed into the network using the ESD file.

A PC programming tool, such as DeviceNet Manager offered by Rockwell, is used to set the node identifier and baud rate. The Statement of Conformance contains the network regulations defined and recommended by the Open DeviceNet Vendor Association (ODVA), that the DeviceNet specifications. Temposonics sensors with Devicenet output can be directly connected to a DeviceNet Bus.

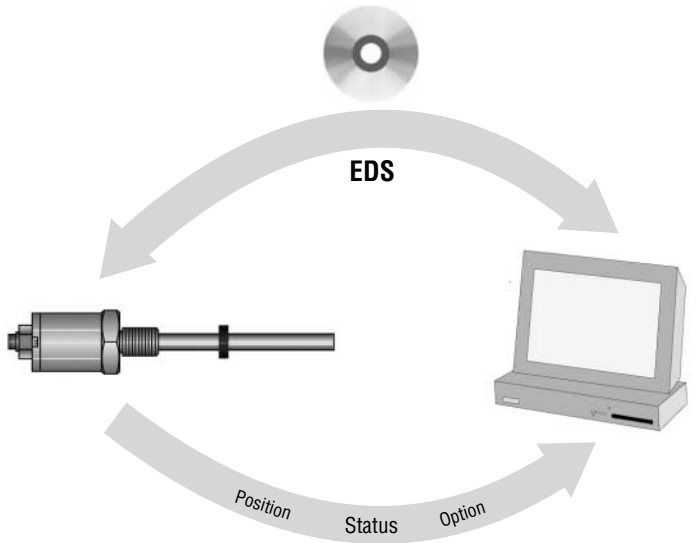

### CAN Bus Interface

Temposonics position sensors fulfill - as slave devices - all requirements of the CAN-Bus (ISO 11898). The sensors electronics convert the displacement measurements into bus oriented outputs and transfer these data directly to the control unit. The bus interface is appropriate for serial data transfer of 500 Mbit/s maximum. Sensor integrated software supports the **DeviceNet** protocol for a comprehensive customized configuration of the sensor-bus system.

### DeviceNet Protocol

The DeviceNet Data Protocol of Temposonics Sensors for standard 1-magnet-measurement always includes following applications data

- Position
- Error detection
- Polling & Bit-strobe communications modes

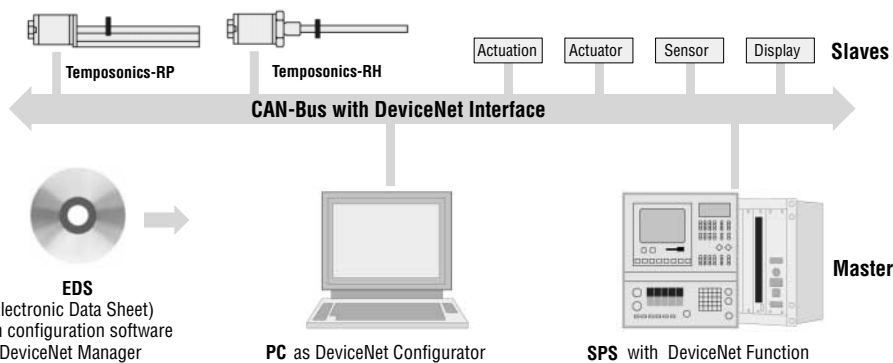

**Technical Data**

<b>Input</b>	
Measured variables	Displacement
Measuring range	Profile 25 - 5000 mm / Rod 25 - 7600 mm
<b>Output</b>	
Interface	CAN-Fieldbus System ISO 11898
Data protocol	DeviceNet Release 2.0
Baud rate, kBit/s	500    250    125
Cable length, m	< 100    < 250    < 500
	<i>The sensor will be supplied with ordered baud rate, which is changeable by customer</i>
Overvoltage protection	up to 36 VDC
<b>Accuracy</b>	
Resolution	
- Displacement	5 µm    2 µm
-Update time	0,5 ms up to 1200 mm / 1,0 ms up to 2400 / 2,0 ms up to 4800 / 4,0 ms up to 7600 mm stroke length
Linearity	< ± 0,01 % F.S. (Minimum ± 40 µm), independent of outside temperatures
Repeatability	< ± 0,001 % F.S. (Minimum ± 2,5 µm)
Temperature coefficient	< 15 ppm/°C
Hysteresis	< 4 µm
<b>Operating conditions</b>	
Magnet speed	Any
Operating temperature	-40 °C ... +75 °C
Dew point, humidity	90% rel. humidity, no condensation
Protection	Profile style: IP65 / Rod style: IP67, IP68 for cable outlet
Shock test	100 g, single hit, IEC-Standard 68-2-27
Vibration test	15g / 10 - 2000 Hz, IEC-Standard 68-2-6
Standards, EMC test	Electromagnetic emission EN 50081-1 Electromagnetic immunity EN 50082-2 EN 61000-4-2/3/4/6, Level 3/4, Criterium A, CE-qualified
<b>Form factor, material</b>	
Diagnostic display	LEDs beside connector
<u>Profile model:</u>	
Sensor head	Aluminum
Sensor stroke	Aluminum
Position magnet	Magnet slider or removable U-magnet
<u>Rod model:</u>	
Sensor head	Aluminum
Rod with flange	Stainless steel 1.4301 / AISI 304
-Pressure rating	350 bar, 700 bar peak
Position magnet	Ring magnets, U-magnets
<b>Installation</b>	
Mounting position	Any orientation
Profile	Movable mounting clamps or T-slot nuts M5 in base channel
U-Magnet, removable	Mounting plate and screws from antimagnetical material
Rod	Threaded flange M18 x 1,5 or 3/4" -16 UNF-3A, Hex nut M18
Position magnet	Mounting plate and screws from antimagnetical material
<b>Electrical connection</b>	
Connection type	5 pin DeviceNet connector M12x1
Input voltage	24 VDC (-15 / +20 %)
- Polarity protection	up to -30 VDC
- Overvoltage protection	up to 36 VDC
Current drain	90 mA typical
Ripple	< 1 % S-S
Electric strength	500 V (DC ground to machine ground)

**Linearity protocol**

Temposonics-RP, stroke 2500 mm  
Tolerance allowed: ± 0,25 mm  
Tolerance measured: ± 0,116 mm  
uncorrected

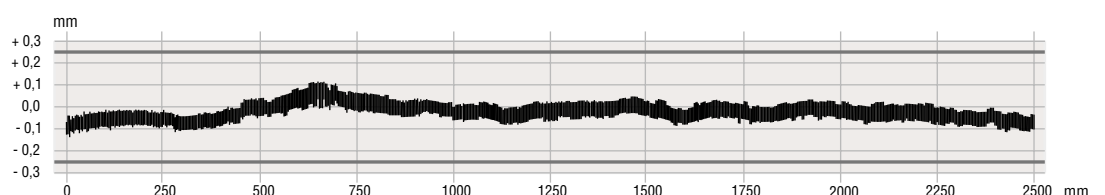

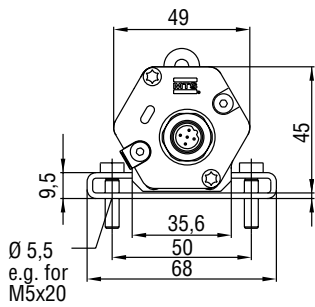

Connector outlet D51

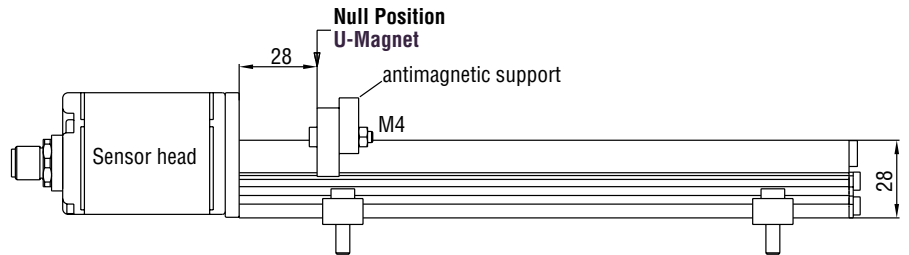
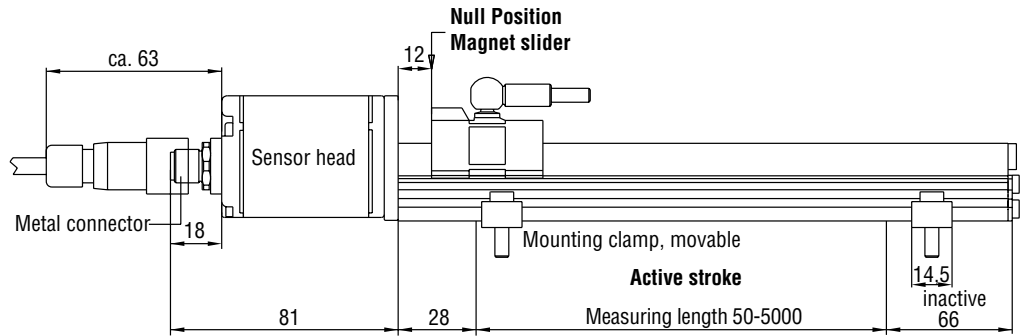

**Selection of position magnets (on delivery)**

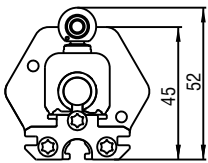

**Magnet slider S**  
Part No. 252 182

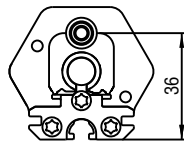

**Magnet slider V**  
Part No. 252 184

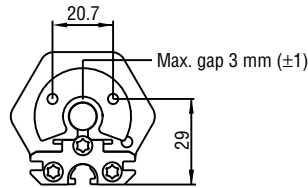

**U-Magnet M OD33**  
Part No. 251 416-2

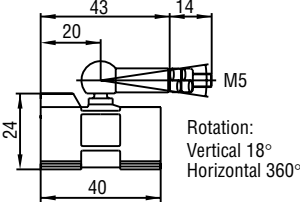

GFK, Magnet Hardferrite  
Weigth ca. 30 g  
Operating temperature:  
-40 ... +75°C

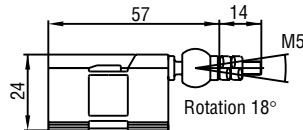

GFK, Magnet Hardferrite  
Weigth ca. 30 g  
Operating temperature:  
-40 ... +75°C

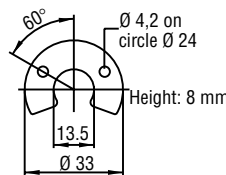

Composite PA-Ferrite-GF20  
Weigth ca. 11g  
Operating temperature:  
-40 ... +100°C  
Surface pressure max. 90 N/mm<sup>2</sup>  
Fastening Torque for M4 screws max. 1 Nm

**Stable Profile Design**

**Temposonics-RP** offers modular construction, flexible mounting configurations and easy installation. Position measurement is contactless via two versions of permanent magnets.

- A sliding magnet running in profile housing rails. Connection with the mobile machine part is via a ball jointed arm to taking up axial forces.
- A floating magnet, mounted directly on the moving machine part, travels over the profile at a low distance. Its air-gap allows the correction of small misalignments at installation.

**Connection types**

**Connector outlet D51**  
5 pin male receptacle M12x1

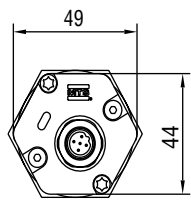

Connector outlet D51

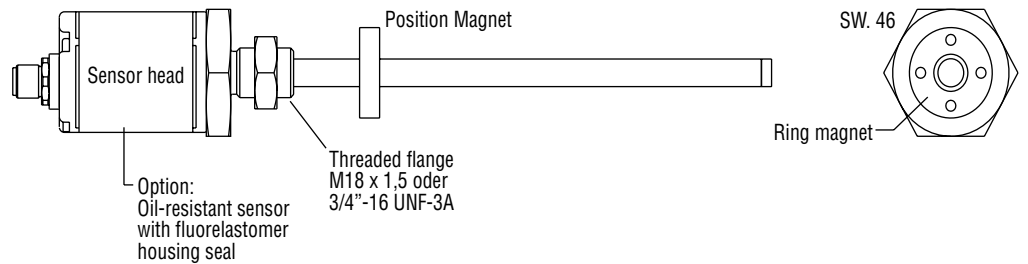
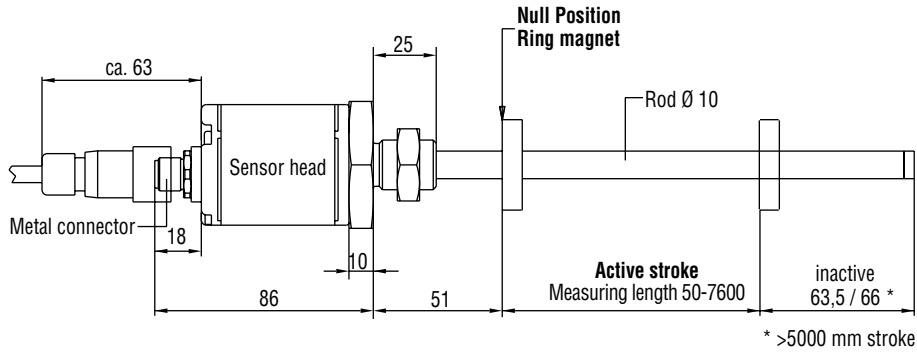

**Selection of position magnets (not on delivery)**

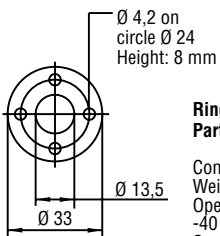

**Ring magnet OD33**  
**Part No. 201 542-2**

Composite PA-Ferrite-GF20  
Weight ca. 14g  
Operating temperature:  
-40 ... +100°C  
Surface pressure max. 40 N/mm<sup>2</sup>  
Fastening Torque for M4 screws max. 1 Nm

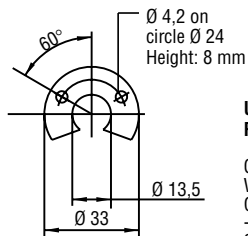

**U-magnet M OD33**  
**Part No. 251 416-2**

Composite PA-Ferrite-GF20  
Weight ca. 11g  
Operating temperature:  
-40 ... +100°C  
Surface pressure max. 40 N/mm<sup>2</sup>  
Fastening Torque for M4 screws max. 1 Nm

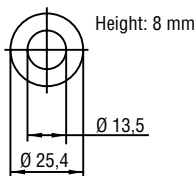

**Ring magnet OD25,4**  
**Part No. 400 533**

Composite: PA-Ferrite  
Weight ca. 10g  
Operating temperature:  
-40 ... +100°C  
Surface pressure max. 40 N/mm<sup>2</sup>

**High Pressure Rod Design**

Temposonics-RH with a pressure-resistant stainless steel flange and sensing rod is suitable for use in hydraulic cylinders and externally in all applications where space is a problem. Position measurement is via ring or U-magnets travelling along the sensing rod without any mechanical contact.

**Advantage...**  
the completely operable sensor cartridge can be replaced for servicing easily without opening the fluid circuit.

## Flexible installation in any position

### Profile model

Normally, the sensor is firmly installed - fixed on a straight surface of the machine with movable mounting clamps or M5 screws in base channel - whilst the magnet is mounted at the mobile machine part.

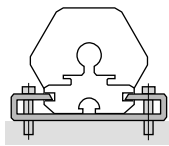

Mounting clamp with screws M5x20  
Tightening torque: max. 5 Nm

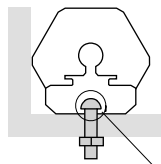

T-slot Nut in base channel

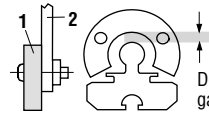
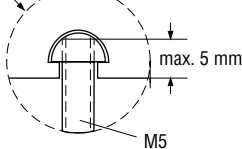

Do not exceed max. gap of 3 mm ( $\pm 1$ )

- 1 U-Magnet
- 2 Mounting plate and screws non-ferrous material

### Rod model

Mount the sensor via flange thread or a hex nut. If possible, non-magnetizable material should be used for mounting support (dimensions as shown). With horizontal mounting, longer sensors (from 1 meter) must be provided with mechanical support.

### Hydraulic sealing

Recommended is sealing of the flange facing with O-Ring (e.g. 22,4 x 2,65) in a cylinder cover nut or an O-Ring 15,3 x 2,2 in undercut.

### Minimum assembly distance

1. Non-magnetizable material

2. Magnetizable material

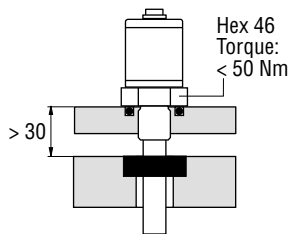

Recommended hydraulic sealing

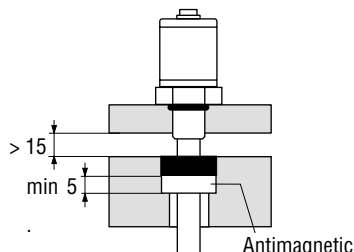

Alternative sealing  
O-Ring 15,3 x 2,2

Wiring	Pin	Function
	1	shield
	2	+24 VDC (+20% / -15%)
	3	DC Ground
	4	CAN (+)
	5	CAN (-)

Male insert sensor plug rear of cable connector

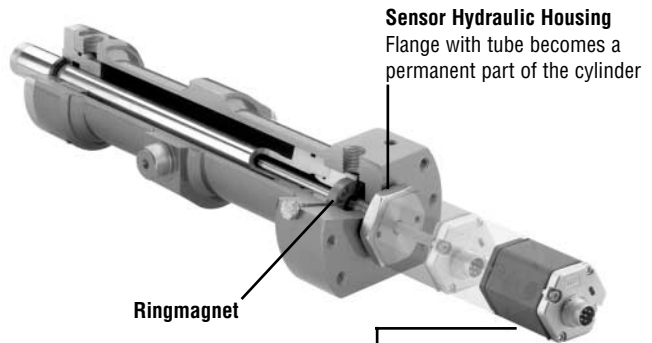

Sensor Cartridge  
Electronic head + sensor element, easy to replace in field with two screws M4 (2,5 mm hexagon socket)

### Cylinder installation

When used for direct stroke measurement in fluid cylinders, the sensor's high pressure, stainless steel rod installs into a bore in the piston head/rod assembly as illustrated. That guarantees a longlife and trouble-free operation - independent of used hydraulic fluid.

The sensor cartridge can be removed from the flange and rod housing while still installed in the cylinder. This procedure allows quick and easy sensor cartridge replacement, without the loss of hydraulic pressure.

### Connector plug (recommended, not on delivery)

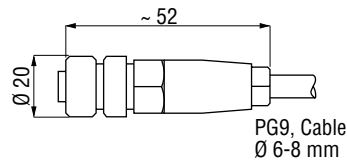

5 pol. female connector M12x1  
DeviceNet "Micro"  
Part No. ST 933 171-100

**Notice!**  
DeviceNet cable specification:  
Thin cable, Table B.3 - B.6  
e.g. Belden YR 399 39 E34 972

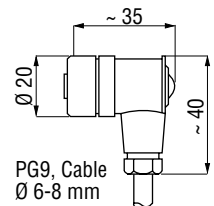

5 pol. female connector M12x1  
DeviceNet "Micro"  
insert adjustable in 90° positions  
Part No. ST 933 176-100



**[www.mtssensor.de](http://www.mtssensor.de)**  
**[www.temposonics-shop.de](http://www.temposonics-shop.de)**  
**Service Hotline: 01805 - mtssensor**

© MTS Temposonics® R-Series Temposonics RPRH DeviceNet 14112006e - Alterations reserved

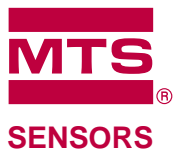

**Germany**  
MTS Sensor Technologie  
GmbH & Co. KG  
Auf dem Schüffel 9  
D-58513 Lüdenscheid  
Tel.: +49-2351-9587-0  
Fax: +49-2351-56491  
[info@mtssensor.de](mailto:info@mtssensor.de)  
[www.mtssensor.de](http://www.mtssensor.de)

**USA**  
MTS Systems Corporation  
Sensors Division  
3001 Sheldon Drive  
Cary, NC 27513, USA  
Tel.: +1-919-677-0100  
Fax: +1-919-677-0200  
[info@mtssensors.com](mailto:info@mtssensors.com)  
[www.mtssensors.com](http://www.mtssensors.com)

**Japan**  
MTS Sensors Technology Corp.  
Ushikubo Bldg.  
737 Aihara-cho, Machida-shi  
Tokyo 194-0211, Japan  
Tel.: +81-42-775-3838  
Fax: +81-42-775-5516  
[info@mtssensor.co.jp](mailto:info@mtssensor.co.jp)  
[www.mtssensor.co.jp](http://www.mtssensor.co.jp)