

# Temposonics®

Absolute, Non-Contact Position Sensors

## R-Series EtherCAT®

**Temposonics®-RP and RH**  
Measuring length 25 - 7600 mm



**Advanced Communication  
... offers Multi-Position Measurement**

- Rugged Industrial Sensor
- Linear and Absolute Measurement
- LEDs for Sensor Diagnostics
- Non-contact Sensing with Highest Durability
- Superior Accuracy: Linearity better 0,01 % F. S.
- Resolution 1  $\mu\text{m}$
- Repeatability 0,001 % F.S.
- Direct EtherCAT Output
- Displacement + Velocity with 5 Magnets
- Displacement with up to 20 Magnets

## Sensor Diagnostic display

Integrated LEDs (green/red) provide basic visual feedback for normal sensor operation and troubleshooting.

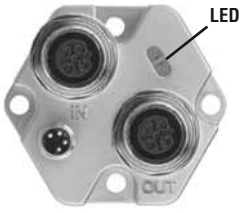

Green	Red	Description
Flashing	OFF	Normal function
Flashing	ON	Magnet not detected or Wrong quantity of magnets
Further diagnostic features programmable.		

## Characteristics of the EtherCAT® sensor

### Sensor's output

- Position as an absolute value
- Velocity and direction of the drive
- Diagnostics (Status information)

### The EtherCAT® Interface

The sensor fulfils the requirements of the EtherCAT field-bus and can be connected as a slave to this bus system. EtherCAT is an open field-bus system which is based on the EtherNet technology (IEEE 802.3) with a high data rate, short response time and a good real-time performance, it is standardized in the IEC/PAS 62407 and it is part of the ISO 15745-4. The integration in the IEC 61158, IEC 61784 and IEC 61800-7 is in the way.

It is very easy to implement the Temposonics® sensor with the EtherCAT interface into an EtherCAT field-bus system. The System-Manager (e. g. TwinCAT from Beckhoff) gets all the parameters of the sensor from the XML-file, which part of the delivery. There are no settings on the sensor.

The measurement can be synchronized by the PLC, by switching the sensor to the "distributed clock mode" (1 to 5 magnets only).

## Operation Mode

There are two versions available:

### E101 1-5 magnet measurement

Measuring in parallel the position and velocities of up to 5 magnets.

The data telegram contains from each magnet:

- Position (32 bit)
- Velocity (32 bit)
- Long status information (16 bit)

### E102 1-20 multi-magnet measurement

Measuring in parallel the positions of up to 20 magnets.

The data telegram contains from each magnet:

- Position (32 bit)
- Velocity (32 bit)
- Long status information (16 bit)

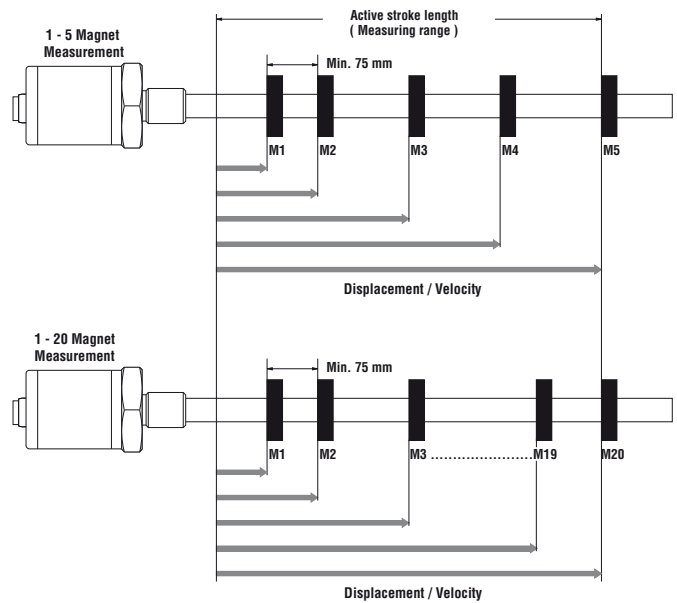

**Technical Data****Input**

Measured variable	Displacement / Velocity 1-5 magnet measurement option 1-20 magnet measurement
Measuring length	Profile 25 - 5000 mm / Rod 25 - 7600 mm

**Output**

Output signal	EtherCAT Ethernet Control Automation Technology
Data format	EtherCAT 100 Base-Tx, fast Ethernet
Data transmission rate	100 MBit/s max.

**Accuracy**

Resolution	
- Displacement	1 ... 1000 $\mu\text{m}$ selectable
- Speed	1 $\mu\text{m/s}$ (Quality rating) adjustable according to velocity and measuring length
Linearity	< $\pm 0,01$ % F.S. (Minimum $\pm 50 \mu\text{m}$ ) Option internal linearisation Linearity tolerance: <u>RP/RH</u> < 300 mm: typ. $\pm 15 \mu\text{m}$ , max. $\pm 25 \mu\text{m}$ , > 300 ... 600 mm: typ. $\pm 20 \mu\text{m}$ , max. $\pm 30 \mu\text{m}$ > 600 ... 1200 mm: typ. $\pm 30 \mu\text{m}$ , max. $\pm 50 \mu\text{m}$ <u>RP</u> 1200 ... 3000 mm: typ. $\pm 45 \mu\text{m}$ , max. $\pm 90 \mu\text{m}$ , 3 ... 5 m: typ. $\pm 85 \mu\text{m}$ , max. $\pm 150 \mu\text{m}$
Repeatability	< $\pm 0,001$ % F.S. (Minimum $\pm 2,5 \mu\text{m}$ )
Cycle time	Measuring length dependent
Data transmission rate	$\leq 10$ KHz (Oversampling is active while the scanning cycle is shorter than the measuring cycle.)
Temperature coefficient	< 15 ppm/ $^{\circ}\text{C}$
Ripple	< 5 $\mu\text{m}$
Hysteresis	< 4 $\mu\text{m}$

**Operating conditions**

Magnet speed	any
Operating temperature	-40 $^{\circ}\text{C}$ ... +75 $^{\circ}\text{C}$
Dew point, humidity	90 % rel. humidity, no condensation
Protection	Profile: IP65, Rod: IP67, if mating connector is correctly fitted, RS: IP69K
Shock test	100 g single hit, IEC-Standard 68-2-27
Vibration test	15 g / 10 - 2000 Hz, IEC-Standard 68-2-6
Standards, EMC test	Electromagnetic emission EN 61000-6-4, CISPR 16 Electromagnetic immunity EN 61000-6-2 EN 61000-4-2/3/4/6, Level 3/4, Criterium A, CE-qualified

**Design, Material**

Diagnostic display	LEDs beside connector
Profile model:	
Sensor head	Aluminum
Sensor stroke	Aluminum
Position magnet	Magnet slider or removable U-magnet
Rod model:	
Sensor head	Aluminum
Rod with flange	Stainless steel 1.4301 / AISI 304
Pressure rating	350 bar, 700 bar peak
Position magnet	Ring magnets, U-magnets

**Installation**

Mounting position	any orientation
Profile	Movable mounting clamps or T-slot nuts M5 in base channel
U-Magnet, removable	Mounting plate and screws from antimagnetical material
Rod	Threaded flange M18 x 1,5 or 3/4" -16 UNF-3A, Hex nut M18
Position magnet	Mounting plate and screws from antimagnetical material

**Electrical connection**

Connection type	2 x 4 pin connector M12-D
Input voltage	24 VDC (-15 / +20 %)
- Polarity protection	up to -30 VDC
- Overvoltage protection	up to 36 VDC
Current drain	80 mA typical
Ripple	< 1 % S-S
Electric strength	500 VDC (DC ground to machine ground)

## Stable Profile Design

Tempsonics®-RP offers modular construction, flexible mounting configurations and easy installation. Position measurement is contactless via two versions of permanent magnets.

- A sliding magnet running in profile housing rails. Connection with the mobile machine part is via a ball jointed arm to taking up axial forces.
- A floating magnet, mounted directly on the moving machine part, travels over the profile at a low distance. Its air-gap allows the correction of small misalignments at installation.

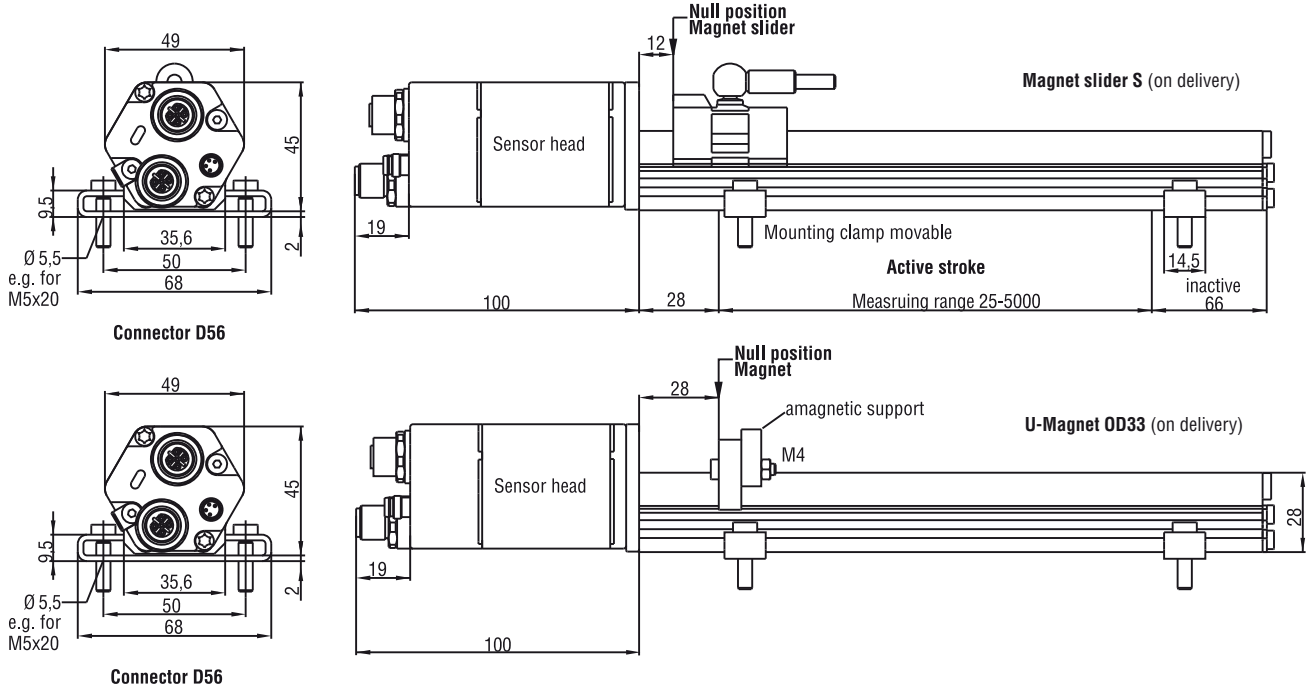

Connection	BUS In / Out	Pin	Cable	Function
View Connector side Sensor		1	yellow	Tx+
		2	white	Rx+
		3	orange	Tx-
		4	blue	Rx-

Input voltage	Pin	Cable	Function
	1	brown	+24 VDC (-15/+20%)
	2	white	do not connect
	3	blue	0 V (GND)
	4	black	do not connect

All dimensions in mm

Standard position magnet upon delivery (see chapter Accessories)

### Position magnets

Magnet slider S (Part No. 252 182)  
 Magnet slider V (Part No. 252 184)  
 U-Magnet OD33 (Part No. 251 416-2)

### Connection types

Cable connector (Part No. 530 066)  
 Cable connector (Part No. 530 064)  
 4 pin Bus cable connector (Part No. 370 523)

## High Pressure Rod Design

Temposonics®-RH with a pressureresistant stainless steel flange and sensing rod is suitable for use in hydraulic cylinders and externally in all applications where space is a problem. Position measurement is via ring or U-magnets travelling along the sensing rod without any mechanical contact.

### Advantage...

the completely operable sensor cartridge can be replaced for servicing easily without opening the fluid circuit.

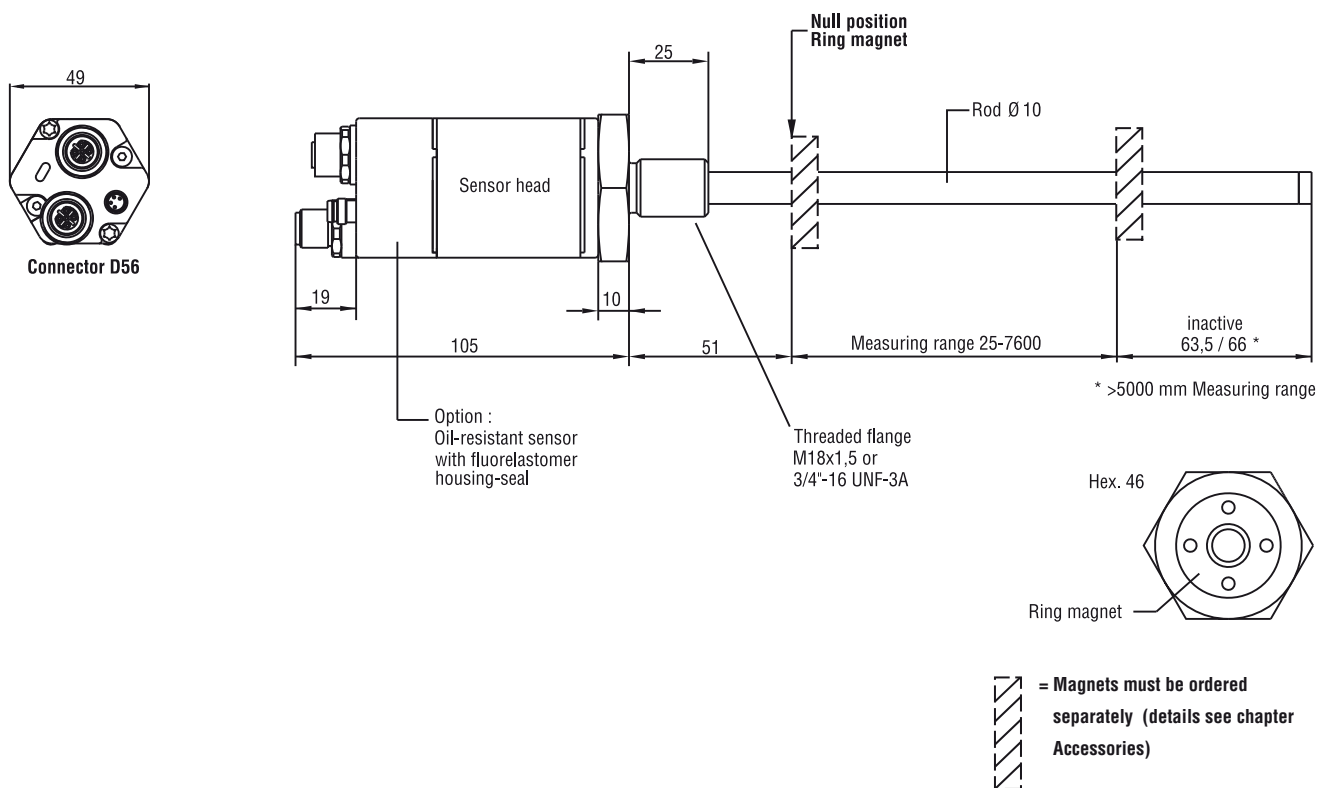

### Standard Position Magnets (not on delivery, please order seperatly)

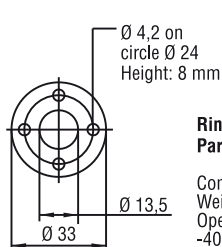

**Ring magnet OD33**  
Part No. 201 542-2

Composite PA-Ferrite-GF20  
Weigth ca. 14 g  
Operating temperature:  
-40 ... +100°C  
Surface pressure max. 40 N/mm<sup>2</sup>  
Fastening Torque for M4 screws max. 1 Nm

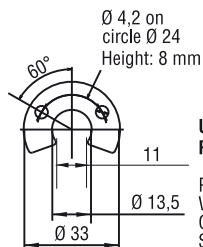

**U-Magnet OD33**  
Part No. 251 416-2

PA-Ferrit-GF20  
Weigth ca. 11 g  
Operating temperature: -40 ... +100°C  
Surface pressure max. 40 N/mm<sup>2</sup>  
Fastening torque for M4 screws max. 1 Nm

All dimensions in mm

Standard position magnet not on delivery (see chapter Accessories)

#### Position magnets

Ring magnet OD33 (Part No. 201 542-2)  
Ring magnet OD25,4 (Part No. 400 533)  
U-Magnet OD33 (Part No. 251 416-2)

#### Connection types

Cable connector (Part No. 530 066)  
Cable connector (Part No. 530 064)  
4 pin Bus cable connector (Part No. 370 523)



## MOUNTING / INSTALLATION RP + RH

### Flexible Installation in any Position

#### Profile Model

Normally, the sensor is firmly installed - fixed on a straight surface of the machine with movable mounting clamps or M5 screws in base channel (2 mounting clamps up to 1250 mm + 1 clamp for every 500 mm) - whilst the magnet is mounted at the mobile machine part.

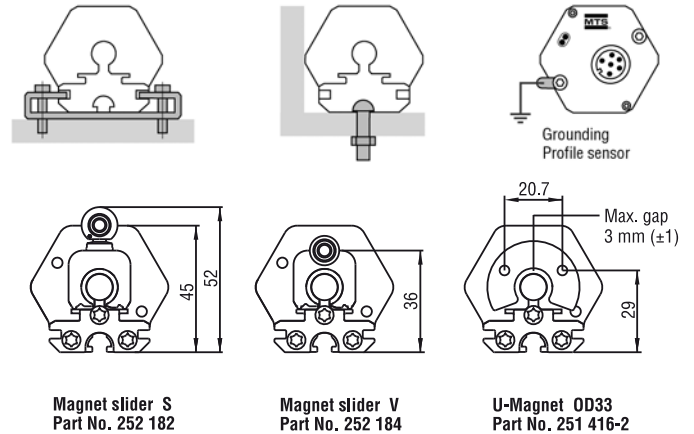

#### Rod Model

Mount the sensor via flange thread or a hex nut. If possible, non-magnetisable material should be used for mounting support (dimensions as shown). With horizontal mounting, longer sensors (from 1 meter) must be provided with mechanical support.

#### Hydraulic Sealing

Recommended is sealing of the flange facing with O-Ring (e.g. 22,4 x 2,65) in a cylinder cover nut or an O-Ring 15,3 x 2,2 in undercut.

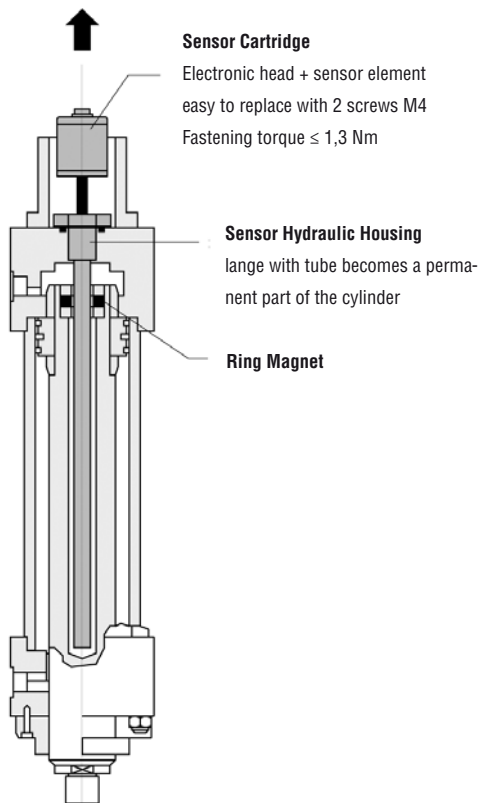

### Minimum assembly distance

#### 1. Non-magnetisable material

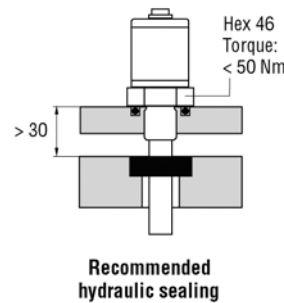

#### 2. Magnetisable material

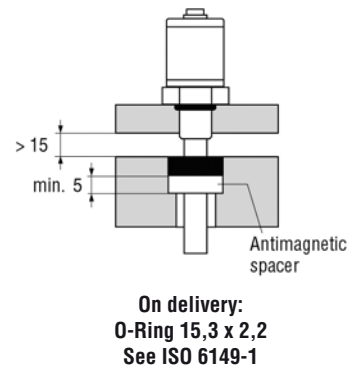

### Cylinder Installation

When used for direct stroke measurement in fluid cylinders, the sensor's high pressure, stainless steel rod installs into a bore in the piston head/rod assembly as illustrated. That guarantees a longlife and trouble-free operation - independent of used hydraulic fluid.

The sensor cartridge can be removed from the flange and rod housing while still installed in the cylinder. This procedure allows quick and easy sensor cartridge replacement, without the loss of hydraulic pressure.

# Temposonics®

Absolute, Non-Contact Position Sensors











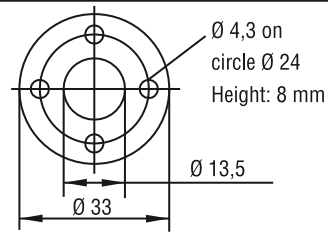

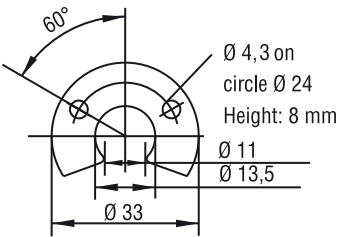
## Accessories

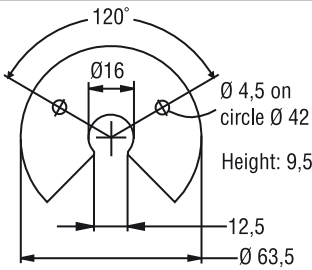

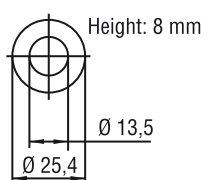
- Position Magnets
- Floats
- Connectors
- Clamps
- Cables
- Programming Tools
- High Pressure Housing, ...

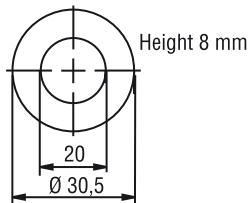
## ACCESSORIES R-SERIES

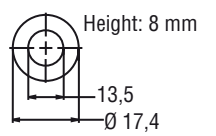

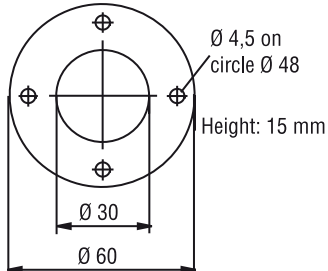







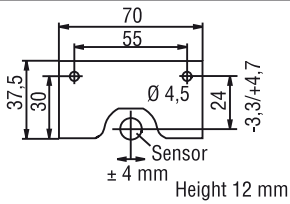

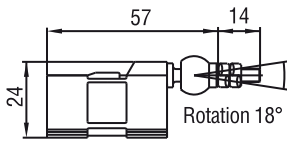

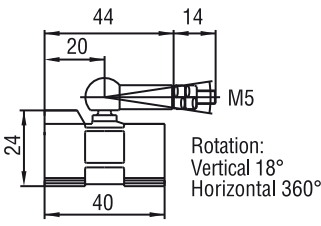
Position Magnets, Floats, Connectors, Clamps, Cables and Programming Tools

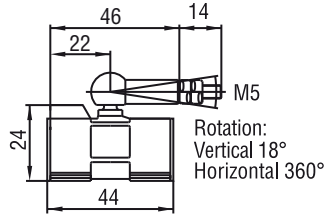
Product	Dimension	Material	Application
 <p><b>Standard magnet</b> Ring magnet OD33 Part No. 201 542-2</p>	 <p>Ø 4,3 on circle Ø 24 Height: 8 mm Ø 13,5 Ø 33</p>	<p>Composite PA-Ferrite-GF20 Weight ca. 14 g Operating temperature: -40 ... +100°C Surface pressure max. 40 N/mm<sup>2</sup> Fastening Torque for M4 screws max. 1 Nm</p>	<p>RH, RF, RD4  marked version for sensors with linearity correction option (LCO): <b>Part No. 253 620</b></p>
 <p><b>Standard magnet</b> U-magnet OD33 Part No. 251 416-2</p>	 <p>60° Ø 4,3 on circle Ø 24 Height: 8 mm Ø 11 Ø 13,5 Ø 33</p>	<p>Composite PA-Ferrite-GF20 Weight ca. 11 g Operating temperature: -40 ... +100°C Surface pressure max. 40 N/mm<sup>2</sup></p>	<p>RH, RF, RP  marked version for sensors with linearity correction option (LCO): <b>Part No. 254 226</b></p>
 <p>U-magnet OD63,5 Part No. 201 553</p>	 <p>120° Ø 16 Ø 4,5 on circle Ø 42 Height: 9,5 12,5 Ø 63,5</p>	<p>PA 66-GF30 Magnets compound-filled Weight ca. 26 g Operating temperature: -40 ... +75°C</p>	<p>RH, RF, RP</p>
 <p>Ring magnet OD25,4 Part No. 400 533</p>	 <p>Height: 8 mm Ø 13,5 Ø 25,4</p>	<p>Composite: PA-Ferrite Weight ca. 10 g Operating temperature: -40 ... +100°C Surface pressure max. 40 N/mm<sup>2</sup></p>	<p>RH, RF, RD4  marked version for sensors with linearity correction option (LCO): <b>Part No. 253 621</b></p>
 <p>Ring magnet OD30,5 Part No. 402 316</p>	 <p>Height 8 mm 20 Ø 30,5</p>	<p>Composite: PA-Ferrite Weight ca. 15 g Operating temperature: -40 ... +100°C Surface pressure max. 40 N/mm<sup>2</sup></p>	<p>RH, RF, RD4</p>
 <p>Ring magnet Part No. 401 032</p>	 <p>Height: 8 mm 13,5 Ø 17,4</p>	<p>PA-Neonbond compound Weight ca. 5 g Operating temperature: -40 ... +100 Surface Pressure max. 20 N/mm<sup>2</sup></p>	<p>RH, RD4 (not for multi-position measurement)</p>
 <p>Ring magnet OD60 Part No. MT 0162</p>	 <p>Ø 4,5 on circle Ø 48 Height: 15 mm Ø 30 Ø 60</p>	<p>Al CuMgPb Magnets compound-filled Weight ca. 90 g Operating temperature: -40 ... +75°C</p>	<p>RH, RF, RD4</p>

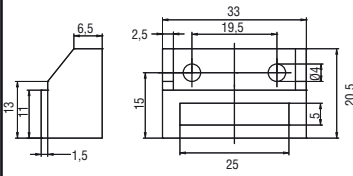
Notice: More magnets available on request. Product pictures may vary from original.

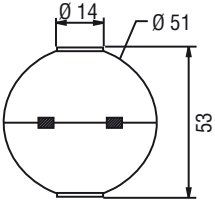
**ACCESSORIES R-SERIES**

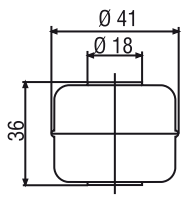

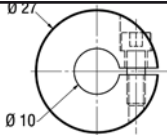







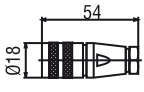

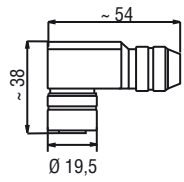
Position Magnets, Floats, Connectors, Clamps, Cables and Programming Tools

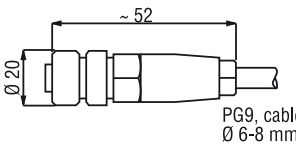
Product	Dimension	Material	Application
 <p>U-magnet 70 Part No. 252 185</p>	 <p>Sensor ± 4 mm Height 12 mm</p>	<p>AlMg4.5Mn, black anodised Magnets compound-filled Weight ca. 75 g Operating temperature: -40...+75°C</p>	<p>RH, RF, RP Resolution min. 10 µm</p>
 <p>Magnet slider V Part No. 252 184</p>	 <p>Rotation 18°</p>	<p>GFK, Magnet Hardferrite Weight ca. 30 g Operating temperature: -40 ... +75°C</p>	<p>RP</p>
 <p>Magnet slider S    Magnet slider G Part No. 252 182    Part No. 253 421</p>	 <p>Rotation: Vertical 18° Horizontal 360°</p>	<p>GFK, Magnet Hardferrite Weight ca. 30 g Operating temperature: -40 ... +75°C <b>Magnet slider S:</b> Ball joint CuZn 39Pb3 nickel plated <b>Magnet slider G - free from float:</b> Socket joint, high-strength plastics Ball joint CuZn39Pb3 nickel plated</p>	<p>RP</p>
 <p>Magnet slider P Part No. 253 673</p>	 <p>Rotation: Vertical 18° Horizontal 360°</p>	<p>GFK, Magnet Hardferrite Weight ca. 30 g Operating temperature: -40 ... +75°C with additional end plates</p>	<p>RP</p>
 <p>Block magnet Part No. 403 448</p>		<p>Weight: ca. 20 g Operating temperature: -40...+75°C</p>	<p>RH, RF, RP Resolution min. 10 µm</p>
 <p>Float 50 mm Part No. 251 447</p>		<p>1.4571 Stainless steel Density: 720 kg/m³ Max. Pressure: &lt; 40 bar Weight: 42 ± 3 g</p>	<p>RH, RF</p>
 <p>Float 41 mm Part No. 200 938-2</p>		<p>1.4404 Stainless steel Density: 740 kg/m³ Max. Pressure: =&lt; 8 bar Weight: 20 ± 2 g</p>	<p>RH, RF</p>
 <p>Collar Part No. 560 777</p>		<p>1.4301 Stainless steel</p>	<p>RH</p>

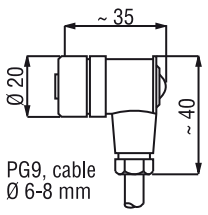
Notice: Product pictures may vary from original.

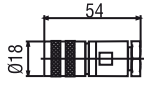
## ACCESSORIES R-SERIES

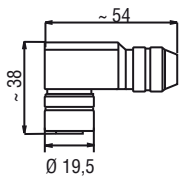

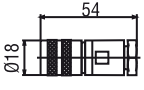







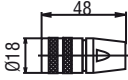

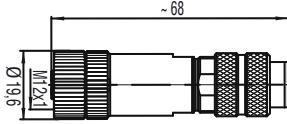
Position Magnets, Floats, Connectors, Clamps, Cables and Programming Tools

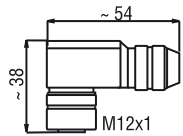
Product	Dimension	Material	Application
 <p>6 pin Connector (for cable Ø 6 mm)  <b>Part No. 370 623 (female)</b>            For cable Ø 6-8 mm  <b>Part No. 370 423</b></p>		Housing: Zinc nickel plated Termination: Solder Contact insert: Silver plated Max. Cable-Ø 6 mm or Ø 8 mm depending on design	Analog CAN
 <p>6 pin Connector M16, 90°  <b>Part No. 560 778 (female)</b></p>		Housing: Zinc nickel plated Termination: Solder Contact insert: Silver plated Max. Cable-Ø 8 mm	Analog CAN
 <p>5 pin connector, M12x1  <b>Part No. 370 618 (female)</b></p>		Housing: PA Termination: Screws clamp Contact insert: (CuZn/Sn) Max. Cable-Ø 6-8 mm	CAN
 <p>5 pin connector, M12x1, 90°  <b>Part No. 370 619 (female)</b></p>		Housing: PA Termination: Screws clamp Contact insert: (CuZn/Sn) Max. Cable-Ø 6-8 mm	CAN
 <p>7 pin Connector, M16  <b>Part No. 370 624 (female)</b></p>		Housing: Zinc nickel plated Termination: Solder Contact insert: Silver plated Cable clamp: PG9 Max. Cable-Ø 8 mm	SSI
 <p>7 pin Connector, M16, 90°  <b>Part No. 560 779 (female)</b></p>		Housing: Zinc nickel plated Termination: Solder Contact insert: Silver plated Max. Cable-Ø 8 mm	SSI
 <p>6 pin Connector, M16  <b>Part No. 370 423 (female)</b>  <b>Part No. 370 427 (male)</b></p>		Housing: Zinc nickel plated Termination: Solder Contact insert: Silver plated Cable clamp: PG9	Profibus (D63)

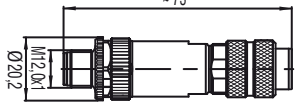
Notice: Product pictures may vary from original.

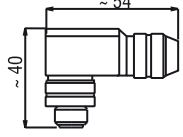
## ACCESSORIES R-SERIES

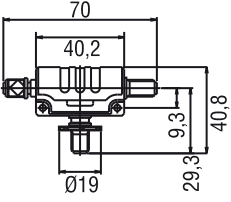

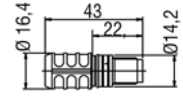







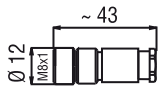

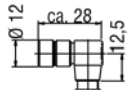
Position Magnets, Floats, Connectors, Clamps, Cables and Programming Tools

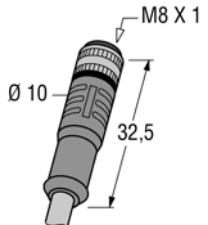
Product	Dimension	Material	Application
 <p>6 pin Bus endplug M16, male <b>Part No. 370 620</b></p>		Housing: Zinc nickel plated Contact insert: Silver plated	Profibus (D63)
 <p>5 pin connector M12-B <b>Part No. 560 885 (female)</b></p>		Housing: Zinc nickel plated Termination: spring-type terminal Contact insert: Silver plated Cable-Ø: 6,5 - 8,5 mm	Profibus (D53)
 <p>5 pin 90° connector M12-B <b>Part No. 370 514 (female)</b></p>		Housing: Zinc nickel plated Termination: spring-type terminal Contact insert: Silver plated Cable-Ø: 6,5 - 8,5 mm	Profibus (D53)
 <p>5 pin connector M12-B <b>Part No. 560 884 (male)</b></p>		Housing: Zinc nickel plated Termination: Srews clamp Contact insert: Silver plated Cable-Ø: 6,5 - 8,5 mm	Profibus (D53)
 <p>5 pin 90° connector M12-B <b>Part No. 370 515 (male)</b></p>		Housing: Zinc nickel plated Termination: Srews clamp Contact insert: Silver plated Cable clamp: M16 Cable-Ø: 6,5 - 8,5 mm Cable type e.g.: K25	Profibus (D53)
 <p>5 pin Bus T-connector M12 <b>Part No. 560 887</b></p>		Housing: PA 66 Contact insert: Silver plated	Profibus (D53)
 <p>5 pin Bus endplug M12 <b>Part No. 560 888</b></p>		Housing: PA 66 Contact insert: Silver plated	Profibus (D53)

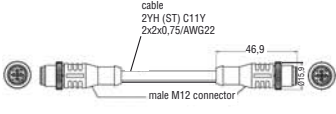
Notice: Product pictures may vary from original.

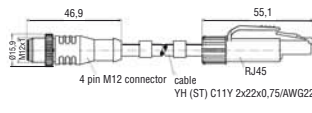
## ACCESSORIES R-SERIES

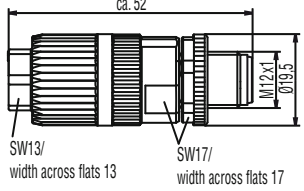









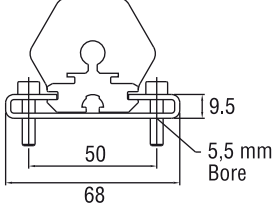

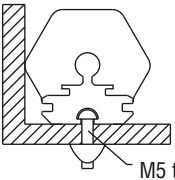
Position Magnets, Floats, Connectors, Clamps, Cables and Programming Tools

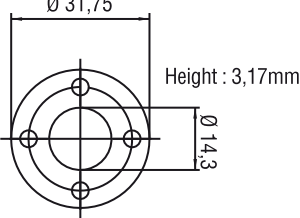
Product	Dimension	Material	Application
 <p>4 pin cable connector M8 <b>Part No. 370 504</b></p>	 <p>~ 43 Ø 12</p>	<p>Housing: Brass nickel plated Termination: Solder Contact insert: Au Max. Cable-Ø 5 mm</p>	<p>Profibus (D53) EtherCAT CAN (D54)</p>
 <p>4 pin cable connector M8, 90° <b>Part No. 560 886</b></p>	 <p>Ø 12 ca. 28 12,5</p>	<p>Housing: PA 66 Termination: Solder Contact insert: Au Max. Cable-Ø 5 mm</p>	<p>Profibus (D53) EtherCAT CAN (D54)</p>
 <p>Cable connector <b>Part No. 530 066</b> <b>Part No. 530 096</b> <b>Part No. 530 093</b></p>	 <p>M8 X 1 Ø 10 32,5</p>	<p>PUR-cable with 4 pin. female connector 5 m length free end 4 x 0,25 mm<sup>2</sup>, shielded for 24 V power supply</p> <p><b>Part No. 530 066</b> = 5 m length <b>Part No. 530 096</b> = 10 m length <b>Part No. 530 093</b> = 15 m length</p>	<p>Profibus (D53) EtherCAT CAN (D54)</p>
 <p>Cable connector <b>Part No. 530 064</b></p>	 <p>46,9 male M12 connector cable 2YH (ST) C11Y 2x2x0,75/AWG22</p>	<p>5 m industrial Ethernet cable (Cat 5e ES) w/2x4 pin M12-connectors (D-coded) PUR-jacket, green</p>	<p>EtherCAT</p>
 <p>Cable connector <b>Part No. 530 065</b></p>	 <p>46,9 55,1 4 pin M12 connector cable YH (ST) C11Y 2x2x0,75/AWG22 RJ45</p>	<p>5 m industrial Ethernet cable (Cat 5e ES) RJ45 connector and M12-connector (D-coded) PUR-jacket, green</p>	<p>EtherCAT</p>
 <p>4 pin Bus cable connector <b>Part No. 370 523</b></p>	 <p>ca. 52 SW13/ width across flats 13 SW17/ width across flats 17 M12 x1 Ø 19,5</p>	<p>IDC technology</p>	<p>EtherCAT</p>
 <p>End cap <b>Part No. 370 537</b></p>		<p>Aluminum</p>	<p>EtherCAT</p>

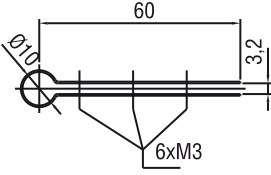
Notice: Product pictures may vary from original.

**ACCESSORIES R-SERIES**

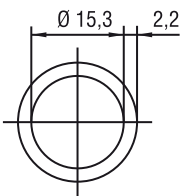
Position Magnets, Floats, Connectors, Clamps, Cables and Programming Tools

Product	Dimension	Material	Application
 Clamp Part No. 400 802	 9.5 50 68 5,5 mm Bore	Stainless steel	RP
 T-Nut Part No. 401 602	 M5 thread	Stainless steel	RP
 Spacer Part No. 400 633	 Ø 31,75 Height : 3,17mm Ø 14,3	Aluminum	RH
 Fixing clip Part No. MT 0200	 60 2,5 Ø10 6xM3	Brass Flat section and fastening screws: non-magnetic material	RH
 Metal protection cap for connector M16 Part No. 403 290			Analog, CAN, SSI, Profibus
 Hex nut Part No. 500 018		Edelstahl	RH-M
 O-ring Part No. 401 133	 Ø 15,3 2,2	Fluorelastomer FPM 75 Operating temperature: -10...+125°C	RH-M
 Cable Part No. 530 032	3 x 2 x 0,14 mm <sup>2</sup> Ø 6 mm	PVC -10 ... +80°C	Standard

Notice: Product pictures may vary from original.

## ACCESSORIES R-SERIES





Position Magnets, Floats, Connectors, Clamps, Cables and Programming Tools

Product	Dimension	Material	Application
 Cable <b>Part No. 530 052</b>	3 x 2 x 0,25 mm Ø 6,8 mm	Pelon PUR -40 ... +80°C	Halogen free Oil-resistant High flexible
 Cable <b>Part No. 530 116</b>	4 x 2 x 0,25 mm²	PUR (-30 ... +90°C)	Water proof wires
 Cable <b>Part No. 530 112</b>	4 x 2 x 0,25 mm²	Teflon (-90 ... +180°C)	Temperature
 Cable <b>Part No. 530 029</b>	7 x 0,14 mm² EMC protected Ø 7 mm	PUR -20 ... +70°C	SSI, CAN
 Cable <b>Part No. 530 040</b>	BUS + feed-in Ø 8 mm	PVC -30 ... +80°C	Profibus-DP D63
 Cable <b>Part No. 530 109</b>	BUS conductor, high flexible cable Ø 8 mm	PUR -30 ... +70°C	Profibus-DP D53
Product	Description		
 Hand-Programmer R-Analog <b>Part No. 253 124</b>	<b>Hand-Programmer R-Analog for 1-Magnet Sensor</b> is for easy teach-in-setups of measuring length and direction on desired Zero/Span positions.		

Notice: Product pictures may vary from original.

**ACCESSORIES R-SERIES**



Position Magnets, Floats, Connectors, Clamps, Cables and Programming Tools

Product	Description
 <p>Cabinet-Programmer Part No. 253 408</p>	<p><b>Cabinet-Programmer R-Analog</b> Cabinet-Programmer R-Analog completes the accessories program of MTS absolute position sensors. The unit can be used for adjusting a connected 1-magnet sensor via the leads, using a simple teach-in procedure in the field.</p>
 <p>USB-Programmer R-Analog Part No. 253 134-1</p>	<p><b>USB-Programmer R-Analog for 1 or 2-Magnets Sensor (incl. Power supply, USB-Cable, Sensor-Cable and CD-ROM)</b> for setting and reading of position and output values by using a PC for</p> <ul style="list-style-type: none"> <li>- Zero/Span Magnet 1</li> <li>- Zero/Span Magnet 2</li> <li>- Velocity range</li> <li>- Free assignment of outputs to measured position or velocity</li> <li>- Error output value (e.g. magnet out of stroke)</li> </ul>
 <p>USB-Programmer R-SSI Part No. 253 135-1</p>	<p><b>USB-Programmer R-SSI (incl. Power supply, USB-Cable, Sensor-Cable and CD-ROM)</b> for setting and reading of</p> <ul style="list-style-type: none"> <li>- Data length</li> <li>- Data format</li> <li>- Resolution</li> <li>- Measuring direction</li> <li>- Synchronous / asynchronous measurement</li> <li>- Offset, begin of the measurement range</li> <li>- Alarm value (Magnet outside)</li> <li>- Measurement filter</li> <li>- Differential measurement</li> </ul>
 <p>Profibus Address-Programmer Kit for D63, D53 or cable connector Part No. 280 640</p>	<p><b>PROFIBUS Address Programmer</b> is used for setting the slave address to Temposonics® sensors with Profibus-DP Interface. The setup of slave address normally is done by the profibus standard service <b>SetSlaveAddress</b>. Since some master systems do not support this standard, or the customer controller system can not handle it, this MTS service tool can be used for the direct setup of the sensor. The programmer and the sensor will be supplied by the included power supply.</p>

Notice: Product pictures may vary from original.

## ACCESSORIES R-SERIES

Position Magnets, Floats, Connectors, Clamps, Cables and Programming Tools

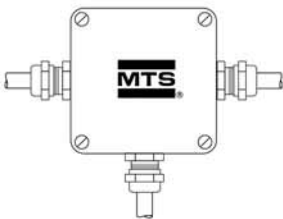
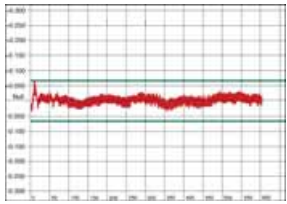
Product	Description
 <p>CANopen Address-Programmer D62 6 pin. female connector M 16 <b>Part No. 252 382-D62</b> 6 pin female 90°-connector M16 <b>Part No. 252 382-D62A</b></p>	<p><b>CANopen Address Programmer</b> is used for setting the Node-Address to Temposonics® sensors with CANopen Interface. The setup of Node-Address normally is done by the CAN Bus standard <b>LMT-Service</b>. Since some master systems do not support this standard, or the customer controller system can not handle it, this MTS service tool can be used for the direct setup of the sensor.</p> <p>All you need for using the programmer is a 24 VDC power supply to the sensor. The programming tool will be supplied from the Temposonics® position sensor.</p>
 <p>Profibus Master Simulator <b>Part No. 401 727</b></p>	<p><b>PROFIBUS Master Simulator</b> The Master Simulator can be used to check the sensors functions and to change the slave address. The magnet positions can be read out and the diagnostic data as well.</p> <p>Cable D 53 <b>Part No. 252 383</b> Cable D63 <b>Part No. 401 726</b></p>
 <p>Display and control unit with SSI input <b>Part No. IX 345</b></p>	<p>Housing: 96 x 48 x 141 mm Cutout: 91 x 44 mm 6-segment LED Display for SSI</p>
 <p>Profibus Filter box <b>Part No. 252 916</b></p>	<p>Housing: 80 x 75 x 58 mm The box is used for EMC-conformal feeding of 24 VDC supply voltage into the Profibus-DP hybrid cable.</p>
 <p>Linearity diagram <b>Part No. 625 096</b></p>	<p>DIN A 4 printout with sensor data and graphic with the linearity gradient Printout with linearity gradient from the sensor. This gradient can be used to choose a special linear segment also for linearity correcture in sections.</p>

Notice: Product pictures may vary from original.

## ACCESSORIES R-SERIES

ATEX [ATmosphere EXplosive]



### Approved Sensors: R-Series

- Analog Output
- CAN Bus [All Versions]
- SSI Output

**Note:** 1. All products are available in Profile and Rod Version.  
2. Signal dependent selectable with PUR, PVC or Teflon cable.

### ATEX Conformity: Marking on MTS Approved Sensor

⊕ II 3G Ex nA II T4  
and/or  
⊕ II 3D tD A22 IP67 T100°C  
TFR: 07 ATEX 027  
-20°C ≤ Ta ≤ 75°C  
Pmax = 4 Watt  
Derated 6,5 K/W ≥ 49°C

### Applicable ATEX Regulations / Directives

**Directive 94/9/EG** ('Manufacturers Directive')  
Sets out directives for equipment manufacturers that are used in potentially explosive atmospheres.

**Related Norms:**  
EN 60079-0:2006, EN 60079-15:2005  
EN 61241-0:2006, EN 61241 - 1:2004

MTS is a certified supplier for displacement sensors intended to be used in hazardous areas of the Category 3 according to the ATEX standard.

- a. In Zone 2 (Gas, Category 3G) in the explosion groups IIA, IIB, IIC.
- b. In Zone 22 (Dust, Category 3D) at dusts with a minimum ignition energy of > 3 mJ.

### Ordering Code

Temposonics® **R**        **M**     **1**     **E X**

#### Model

RP- Profile

RH - Rod

#### Measuring Length in mm

Profile - 0050...5000 mm

Rod - 0050...7600 mm

Standard: up to 1000 in 50 mm steps, greater 1000 in 250 mm steps

Other length upon request.

#### Connection type:

**R02** - 2 m PVC cable w/o connector, Option: R01-R10 (1-10 m)

**P02** - 2 m PUR cable w/o connector, Option: P01-P10 (1-10 m)

**T02** - 2 m Teflon cable w/o connector, Option: T01-T10 (1-10 m)

Note: This options are output signal dependent.

For details refer individual catalog section.

#### Output

Analog / CANbus / SSI

#### Approved Versions

ATEX

## ACCESSORIES R-SERIES

Precision Position Measurement High Pressure Housing



This High Pressure Housing is ATEX EEx approved and UL and cUL approved for use in hazardous locations with Temposonics® position sensors.

The ATEX, UL and cUL approvals cover flammable gases, vapors and liquids.

This housing is made to fit Temposonics® R-Series sensors with analog and digital outputs. Both fixed cable and connector versions can be used. When using a standard sensor in this housing you get a cost efficient solution for use in hazardous locations which also allows easy sensor replacement.

Several design combinations are available to fit your application:

M18 or 3/4" UNF Mounting flange thread - M20 or 1/2" NPT Cable gland thread - long or short - top-mounted, side-mounted, or dual side-mounted cable glands. See Combination Chart.

All parts are made of 316L Stainless steel. The housing is also available in non-approved versions ensuring an outstanding protection to the sensor when used in rugged applications with high humidity and aggressive gases.

### Protection Type:

ATEX:



II 2 G Ex d IIC T5 T<sub>amb</sub> -40°C to +60°C

II 2 D Ex tD 20/A21 IP68 T 100°C

ITS09ATEX16296X

In accordance with EN 60079-0:2006

EN 60079-1:2007, EN 60079-26:2004,

EN 60079-0:2006 and EN 61241-1:2004

Only with ATEX approved cable glands

Class 1, Division 1, Groups A, B, C, and D

hazardous locations, temperature code T5

As to fire, electrical shock and explosion

hazards only UL certificate no. 2PD0.

In accordance with UL 1203 standard.

Only with UL approved cable glands



### Material:

Stainless Steel AISI 316L (1.4404)

### Cable Gland Threads:

M20 x 1,5 or 1/2" NPT

### Ingress protection code:

IP68 (only with IP68 approved cable gland)

### Approved sensors:

G-Series Analog + Digital

L-Series Start / Stop

R-Series Analog

R-Series Profibus

R-Series CANBUS

R-Series SSI

R-Series DeviceNet

### Mounting Flange:

M18 x 1,5 or 3/4" - 16UNF - 3A

### Pressure rating:

350 Bar continuous

### Peak pressure:

530 Bar

### Magnet type:

Ring magnets see page 58

### Level Measurement:

Float on request

Top mounted cable gland

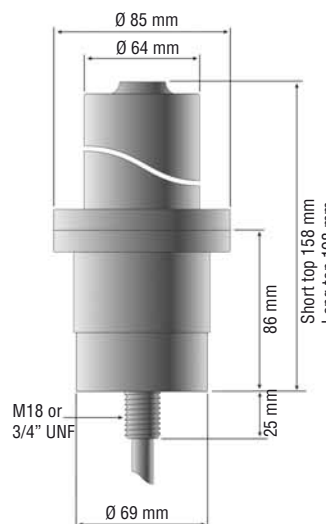

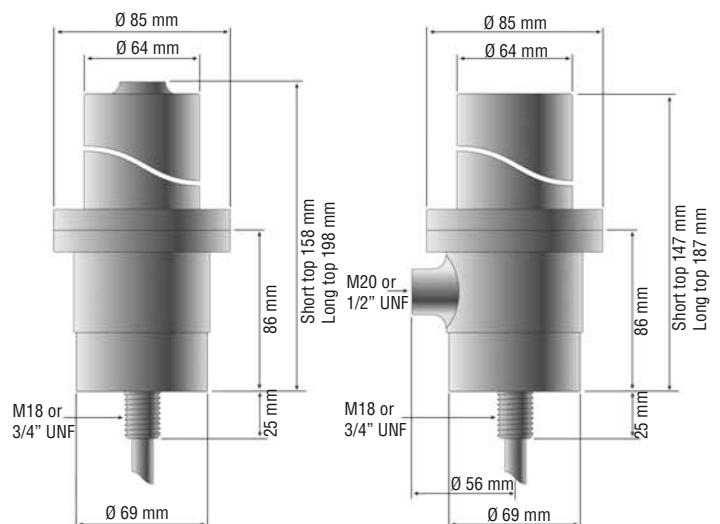

Side mounted cable gland



**ACCESSORIES R-SERIES**

Precision Position Measurement High Pressure Housing

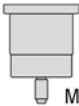
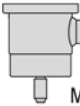
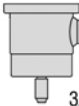
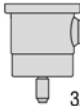
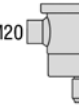
Combination Chart:

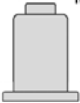
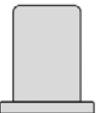
<b>Bottom</b> <b>Top</b>	 M 18	 M 20 M 18	 1/2" NPT 3/4" UNF	 1/2" NPT 3/4" UNF	 M20 M 20 M 18
<b>Approval</b>	<b>ATEX</b>	<b>ATEX</b>	<b>ATEX</b>	<b>UL and cUL</b>	<b>ATEX</b>
 M 20	<b>0100</b>				
		<b>0900</b>	<b>1000 ATEX</b>	<b>1000 UL/cUL</b>	<b>1300</b>
 M 20	<b>0300</b>				
		<b>1700</b>			<b>2100</b>

The long top is needed for Profibus sensors

**Ordering Information:**

Part-No. HPH -XXXX-XXXX-X-XXXXXX

Choose a design combination from the chart

Measuring length 50 - 7600 mm

Approved or Non-approved version

Only for version 1000: Please add type of approval:

- ATEX
- UL/cUL

Example: Approved short housing with M18 mounting threads and one side mounted cable gland with M20 threads and a measuring length of 650 mm:

**HPH-0900-0650-A**

Note!  
 Accessories see data sheet "High Pressure Housing"  
 Order separately: Sensor R-Series RH-B...  
 B = Basic version without hydraulic rod